

Paasche®

VL & VLS Internal Mix - Double Action Airbrushes

INSTRUCTIONS AND PARTS LIST VL/VLS-12/17/2008
Supersedes Instructions & Parts List VL/VLS-11/19/2008

WARNING: Spray materials may be harmful if inhaled or allowed to come into contact with the skin or eyes. Consult the product label and Material Safety Data Sheet supplied for the spray material. Follow all safety precautions. **CAUTION:** Well Ventilated Area Required to remove fumes, dust or overspray. Secure airhose to Airbrush with V-62 Wrench for safety and to prevent air leaks.
Maximum Air Pressure 75 P.S.I.

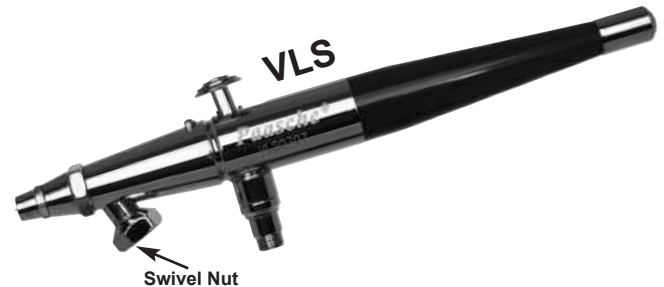
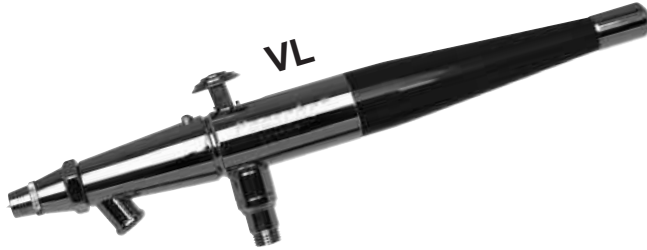

INTRODUCTION:

Paasche® models VL and VLS feature hand crafted construction using quality materials. The bodies are machined brass, polished and chrome plated. Fluid tips are made from nickel silver, needles are stainless steel, the packing washer is Teflon® and the handle is nylon. Either airbrush, preferred by professional and hobbyist alike, permits great flexibility in regulation of color and air without work stoppage. Different size aircaps, tips and needles are quickly interchangeable to allow greater diversity in materials and coverage.

The Paasche® VLS, available in three sizes, is equipped with a threaded connection at the color socket so bottle assemblies can be securely fastened for greater mobility. It can also be used with larger gravity feed containers for production work.

Head Sizes - Patterns - Fluid Thickness

- Size 1 - Tip size .022 inches or .55mm
- Used for fine detail. Pencil Line to 1" patterns
- Paint must be thinned further than 3 & 5 heads
- Size 3 - Tip size .029 inches or .73mm
- Less detail than the size 1 head. 1/32" to 1-1/2" patterns
- Can spray slightly thicker paint than size 1 head
- Size 5 - Tip Size .042 inches or 1.06mm
- Less detail than the size 3 head. 1/16" to 2" patterns
- Can spray slightly thicker paint than size 1 head

Working Pressures:

- Operating pressures 20-55 PSI; Maximum pressure 75 PSI
- 20-30 PSI is best for detail spraying w/ properly thinned paint
- Use the higher pressures for thicker material where fine detail is not critical or thin the paint to allow lower pressures.

Equipment Set-up:

The Airbrush is held in the same manner as a pen, with the index finger comfortably over the finger button.

1. Attach airhose to air supply and to airbrush. If regulator set pressure between 20 -30 PSI.
2. For VL attach the color cup or bottle assembly to color socket. For VLS tighten lock nut to bottle with wrench
3. Remove Head Protecting Cap-#6 page 2.

Airbrush Operation:

1. Press down on Finger Button to release air and pull back on button to control quantity of color.
2. To spray a fine line without heavy ends, start moving the airbrush without release of color. Then start the color at the beginning of line and stop the color at the end, but continue the motion of the airbrush after the color has stopped.
3. Practice this movement until you can spray a fine line or a broad pattern without heavy build up at the beginning or end of your strokes.
4. Speed of movement controls density of color and fading effects at beginning and end of strokes.
5. For detail, hold the airbrush very close to the surface push down for air and pull back very slowly on the Finger Button to release a small amount of paint.
6. For background work and broad effects, hold the airbrush away from the work surface and pull back on Finger Button to release required amount of color.
7. For Stippling remove the aircap, push down on the trigger and pump the trigger forward and back. Adjust the air pressure between 15 and 50 PSI for desired stipple effect.
8. For more instruction see the "22 Airbrush Lessons for Beginners" booklet enclosed with your airbrush.

Paasche Airbrush Company
4311 North Normandy Avenue
Chicago, IL 60634-1395

Phone: 773-867-9191 • Fax: 773-867-9198
Website: paascheairbrush.com
E-Mail: info@paascheairbrush.com

Printed in the U.S.A.

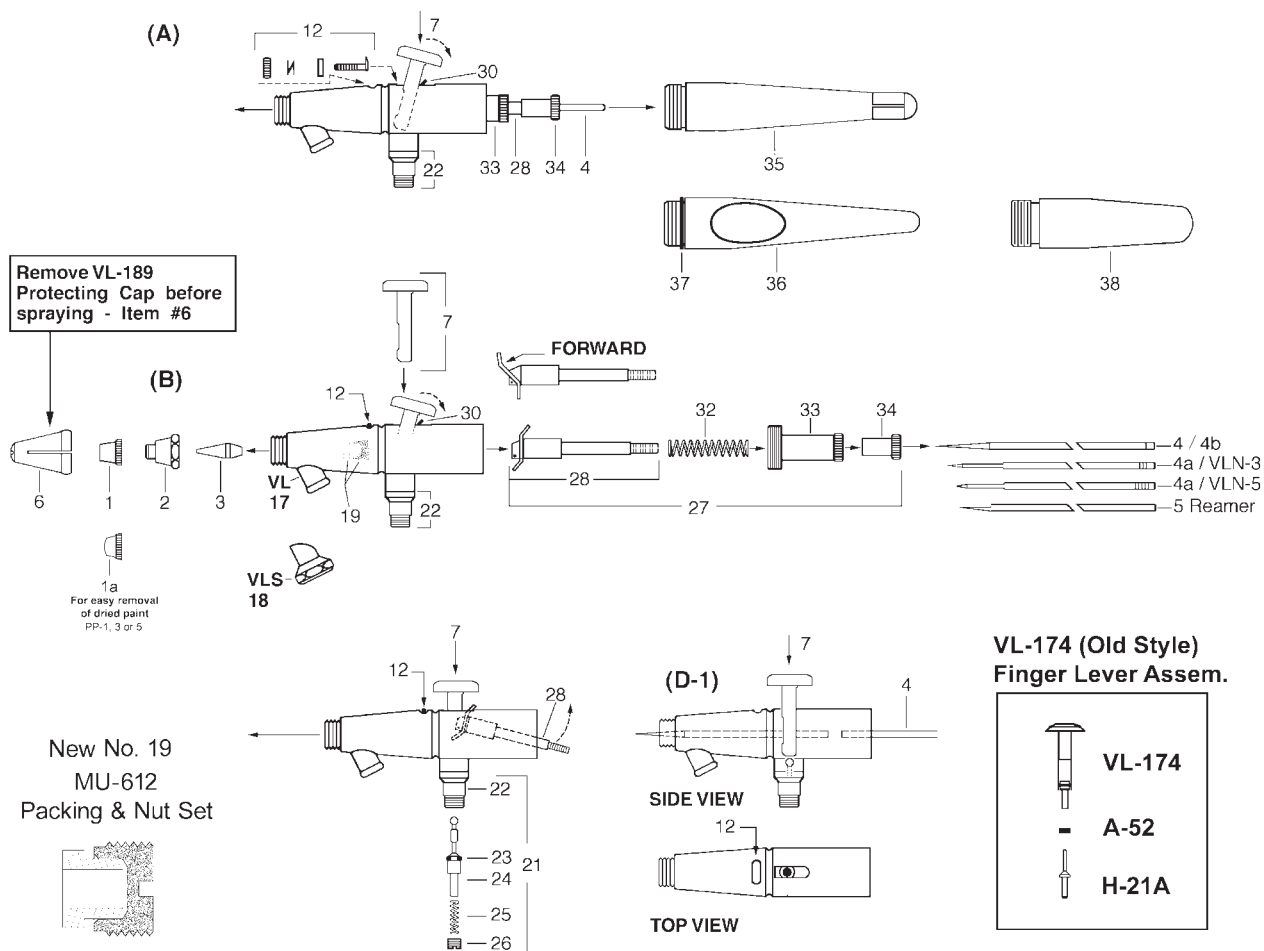

VL and VLS AIRBRUSH PARTS

NO.	PART	DESCRIPTION	NO.	PART	DESCRIPTION
2.	VLB	Aircap Body	21.	VL-215	Air Valve Assembly (VL & VLS Only)
	VLM-1, 3 or 5	Multiplehead (Specify Size)	22.	VL-20	Valve Casing (VL & VLS)
1.	VLA-1, 3 or 5	Aircap (Specify Size)	23.	A-53	Valve "O" ring (pack of 6)
4 -4b.	VLN-1, 3 or 5	Needle (Specify Size)	24.	VL-214	Valve Plunger (with A-53)
3.	VLT-1, 3 or 5	Tip (Specify Size)	25.	A-22	Valve Spring
4.	VLN-1	Needle (Specify Size)	26.	A-23A	Air Valve Nut
4a.	VLN-3, VLN-5	Needle (Specify Size)	27.	VL-186	Needle Valve Assembly
4b.	VLN-1POL	Polished Needle (Optional Equipment)	28.	VL-191A	Rocker Assembly (Complete)
5.	VL-54	Reamer (Optional Equipment)	32.	VL-140	Spring
6.	VL-189	Head Protecting Cap	33.	VL-136A	Needle Adjusting Sleeve
7.	VL-213	Trigger	34.	VL-141	Locknut
12.	VL-175	Line Adjustment Assembly	35.	VL-134N	Handle
17.	VL-163	Shell Assembly (VL) W/VL-20			
18.	VLS-163	Shell Assembly (VLS) W/VL-20			
19.	MU-612	Teflon® Packing & Packing Nut (sold as set) ©DuPont			
Optional Items:					
	1a.	PP-1, 3 or 5	Paint Picker Aircap for easy removal of dried paint - match to Tip.		
	36.	HVL-202	Standard Length <u>Metal</u> Handle with Cut-Out and "O" Ring		
	37.	VL-224	"O" Ring for HVL-202 Handle		
	38.	HVL-203	Stubby Length <u>Metal</u> Handle		

REMOVING/REPLACING THE NEEDLE AND HANDLE (Illustration A):

1. Unscrew the handle and loosen the Locknut-#34 by turning counterclockwise. Depress the Trigger-#7 and hold in Down position while removing or inserting the needle. This assures the needle moves freely through the finger lever. Gently remove the needle, rotating if necessary, Do NOT force out!
2. A loose needle can cause sputtering if there is any air leakage around the needle and Packing-#19. If there is no noticeable drag on the needle by the packing then tighten Nut-#19.
3. Inspect the condition of the needle. If it is bent or misshapen in any way, replace it with a new needle. A bent needle can damage or split the Tip-#3 causing bubbles or a rough spray pattern.
4. Hold Trigger in DOWN position, insert the new needle into the Rocker Assembly-#28. Gently push needle through, rotating if necessary, push gently forward until the needle stops in the front of the tip.
5. Release Trigger and tighten Locknut by turning clockwise.

REPLACING THE TRIGGER (Illustration D-1):

If the Trigger-#7 is removed, it must be replaced inside the airbrush shell, before the Rocker Assembly-#28 and needle are re-inserted.

1. Hold the Trigger so the opening in the lever is in-line with the opening in the end of the airbrush shell and the smooth side of the Trigger stem is to the rear. (see D-1).
2. Insert Trigger so the bottom of the stem covers the round top of the valve plunger.
4. Once the Trigger has been inserted into the slot on the top of the shell, you will be able to press down on the Trigger and it will return to the up position when released. Proceed to replace Rocker Assembly and balance of parts as above. The needle when inserted will prevent the removal of the Trigger.

REPLACING THE TIP:

1. Remove handle, loosen Locknut-#34 and withdraw needle about one inch (1").
2. Un-screw the Aircap Body-#2 and remove. The Tip-#3 can now be easily removed by hand. If stuck in shell tap lightly with wrench.
3. Place a new Tip into position and tighten Aircap Body to shell with a wrench. Push needle forward until it seats fully forward in tip and tighten Locknut.

ADJUSTING OR REPLACING WORN PACKING WASHER:

1. If Teflon® Packing-#19 becomes worn or loose it must be tightened or replaced.
2. You will need a small screwdriver to remove or tighten the Packing Nut.
3. When replacing your Teflon® Packing press Packing onto the Packing Nut-#19. Use a small screwdriver to tighten packing nut into shell until it is tight then back out one-half turn, may vary.
4. Now insert needle - you should feel a slight resistance. If too loose or too tight adjust the Packing Nut with screwdriver until you feel some slight resistance.
5. Now completely re-assemble guts of Airbrush.

CLEANING THE AIRBRUSH:

1. Paint passes from the bottle connection forward so the trigger area back will most likely not need cleaning.
2. You can back flush the paint into your bottle by covering the aircap with your finger pressing down on the trigger and pulling slightly back. This forces paint from the fluid passage back into the bottle. **If using open cup, cover before back flushing.**
3. In between color changes or before storing the airbrush attach bottle with paint cleaner and spray until it runs clear.
4. Remove needle and wipe clean then replace.
5. If paint has dried for a time you can remove the front tip, aircap and aircap body for soaking or soak just the front of the airbrush in cleaner.
6. Any paint cleaner is fine. Keep trigger area dry if soaking.

PERSONAL SETTINGS:

- Needle Adjustment Sleeve- Used to increase or decrease spring tension for the Trigger pull back. Thread into the shell until the Trigger stroke feels comfortable. Threading in until it stops can cause the Trigger to jam.
- Line Adjustment Assembly- Used to preset paint flow. When rotated clockwise the Trigger will retract opening the fluid passage. This allows a set paint flow when only pushing down on the Trigger.

TROUBLESHOOTING:Bubbling in cup

1. VLB aircap body #2 needs to be wrench tightened

Skipping or Spitting:

- | | |
|--------------------------------|---|
| 1. Paint too thick | -Reduce with thinner |
| 2. Tip not seated | -Tighten VLB aircap body with wrench |
| 3. Tip split or damaged Needle | -Replace tip or needle |
| 4. Needle or tip dirty | -Clean and replace |
| 5. Air pressure too low | -Increase pressure or thin paint further (need 20 or more PSI to spray most paints) |

Airbrush Not Spraying:

- | | |
|-----------------------------|---|
| 1. Clogged Tip | -Remove tip and clean |
| 2. Needle not moving | -Tighten needle locknut |
| 3. Loose VLB aircap body | -Wrench tighten |
| 4. Low air pressure | -Increase pressure (need 20 or more PSI to spray most paints) |
| 5. Bottle vent hole plugged | -Use needle or pin to clear air hole |

Sprays double line or heavy to one side:

- | | |
|-------------------------------|--|
| 1. Split tip or bent needle | - Replace |
| 2. Dirty tip or needle | - Remove and clean |
| 3. Tip not centered in aircap | - Remove head and clean airbrush seat and tip seat then reassemble. Use wrench for aircap body |

Jammed trigger or poor trigger motion:

- | | |
|----------------------------------|---|
| 1. Adjust Needle Adj. Sleeve | - Screw or unscrew the sleeve to lessen or increase tension on Trigger motion |
| 2. Paint leaking to Trigger area | - Remove guts of airbrush and slightly tighten packing or replace if needed |
| 3. Lubricate needle and Trigger | - Apply lubricant to needle shaft and Trigger slot area |

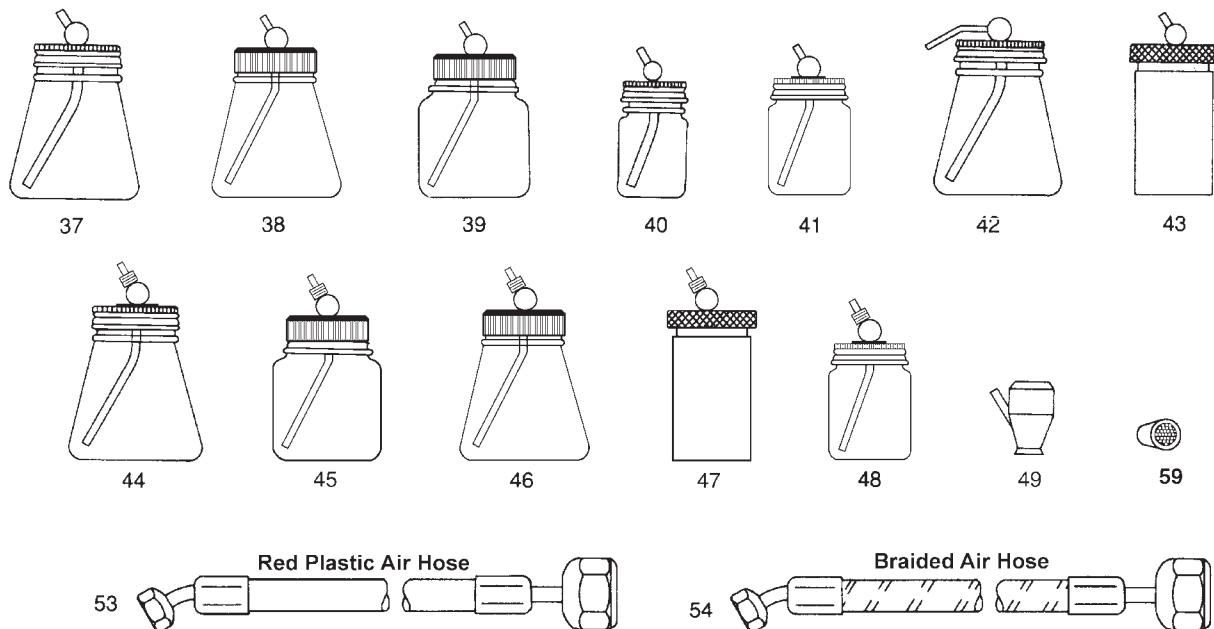

VL and VLS BOTTLE ASSEMBLIES and CUP

* Cup or Bottle for VL Airbrush, ‡ Cup or Bottle for VLS Airbrush

NO.	PART NO.	DESCRIPTION
37.*	VL-3-OZ	3 oz. Glass Bottle Assembly (89cc)
	VL3	3 oz. Metal Cover & Tube Assembly
	H-108	3 oz. Glass Bottle (89cc)
38.*	PCVL-3-OZ	3 oz. Plastic Cover & Metal Tube Assem. (89cc)
	PCVL3	3 oz. Plastic Cover & Metal Tube Assembly
	H-108	3 oz. Glass Bottle (89cc)
39.*	VLP-3-OZ	3 oz. Plastic Cover, Tube & Bottle Assem. (89cc)
	VLP3	3 oz. Plastic Cover & Tube Assembly
	62-17P	3 oz. Plastic Bottle (89cc)
40.*	VL-1/2-OZ	1/2 oz. Glass Bottle Assembly (14.5cc)
	VL1/2	1/2 oz. Metal Cover Assembly W/Gasket
	H-164	1/2 oz. Glass Bottle (14.5cc)
41.*	VL-1-OZ	Color Bottle Assembly (29cc)
	VL1	1 oz. Cover Assembly
	H-99	1 oz. Glass Bottle (29cc)
42.*	VLD-3-OZ	3 oz. Decorator Bottle Assembly (89cc)
	H-108	3 oz. Glass Bottle (89cc)
43.*	VL-2-OZ	Aluminum Cup Assembly (60cc)
	VF-23	2 oz. Aluminum Cup (60cc)
44.‡	VLS-3-OZ	3 oz. Bottle Assembly (89cc)
	VLS3	3 oz. Metal Cover Assembly
	H-108	3 oz. Glass Bottle (89cc)
45.‡	VLPS-3-OZ	3 oz. Plastic Bottle Assembly (89cc)
	VLPS3	3 oz. Plastic Cover & Tube Assembly
	62-17P	3 oz. Plastic Bottle (89cc)
46.‡	PCVLS-3-OZ	3 oz. Plastic Cover & Metal Tube Assem. (89cc)
	PCVLS3	3 oz. Plastic Cover & Metal Tube Assembly
	H-108	3 oz. Glass Bottle (89cc)
47.‡	VLS-2-OZ	Aluminum Cup Assembly (60cc)
	VF-23	2 oz. Aluminum Cup (60cc)
48.‡	VLS-1-OZ	Color Bottle Assembly (29cc)
	VLS1	1 oz. Cover Assembly
	H-99	1 oz. Glass Bottle (29cc)
49.‡*	VL-1/4-OZ	Metal Color Cup (7cc)

NOTE: 3-JG Gasket for 3oz and 2oz bottles
5-G Gasket for 1 oz bottles

AIRHOSES W/FACTORY INSTALLED COUPLINGS

- 53. **HP-1/8** PVC-Red Plastic Airhose W/Couplings
- 54. **A-1/8** Braided Airhose W/Couplings
- 59. **VL-127** Strainer for Teflon® White Color Tube Only

ACCESSORIES (not shown)

- A-34** Hanger
- V-62** Wrench

Recommended Compressors and Accessories



D500 AIR COMPRESSOR (1/8 H.P.) (ETL Listed)
 Economical and suitable for all airbrushes spraying properly thinned fluids. It is capable of delivering up to 35 P.S.I. operating pressure depending on airbrush being used. The Paasche D500 is an oilless piston compressor. It operates on 110-120 Volt, 1 phase, 60Hz, and delivers 4 C.F.M. @ 20 P.S.I. Shipping Weight: 8 lbs. (3.6kg)

D200R AIR COMPRESSOR (1/6 H.P.) with Switch UL Listed & R-75 Regulator
 Perfect for hobbies requiring increased pressure for atomizing heavier materials. Delivers up to 35 psi operating pressure. It operates on 115 Volts, 60Hz, 1.5AMPS and delivers .7 CFM @ 20 psi. Shipping Weight: 13 lbs. (5.9 kg)

DA300R AIR COMPRESSOR (1/6 H.P.) with Switch CSA approved & R-75 Regulator
 1/8 H.P. Piston Compressor with Auto shutoff. Compressor shuts off when airbrush is not in use. Operating pressure is 20 - 30 P.S.I. depending on airbrush being used, delivers up to 35 psi. 120 VAC, 1 Ph, 60 Hz, 1.4 A, 20L/Min. (0.7CFM), Noise 53dB, 1720 rpm. Shipping Weight: 9.14 lbs. (4.6 kgs)

DA400R AIR COMPRESSOR (1/6 H.P.)
 1/6 H.P. Piston Compressor with Auto shutoff. Compressor shuts off when airbrush is not in use. Operating pressure 30 - 50 PSI depending on airbrush being used, delivers up to 55 psi. 110-120VAC, 1 Ph, 60 Hz, 42L/Min. (1.48CFM), 1720 rpm. With R-75 Regulator & Moisture Trap included. Shipping Weight: 12.2 lbs. (5.6 kgs)