



Perfect Appearance Excellent Performance

F4U-4 Corsair

OPERATING MANUAL



Please visit both our **Facebook** fanpage and our homepage for updated product information

WARNING

 **WARNING:** Read the ENTIRE instruction manual to become familiar with the features of the product before operating. Failure to operate the product correctly can result in damage to the product, personal property and cause serious injury.

This is a sophisticated hobby product and NOT a toy. It must be operated with caution and common sense and requires some basic mechanical ability. Failure to operate this Product in a safe and responsible manner could result in injury or damage to the product or other property. This product is not intended for use by children without direct adult supervision.

This manual contains instructions for safety, operation and maintenance. It is essential to read and follow all the instructions and warnings in manual, prior to assembly, setup or use, in order to operate correctly and avoid damage or serious injury.

Safety Precautions and Warnings

As the user of this product, you are solely responsible for operating in a manner that does not endanger yourself and others or result in damage to the product or the property of others. This model is controlled by a radio signal subject to interference from many sources outside your control. This interference can cause momentary loss of control so it is advisable to always keep a safe distance in all directions around your model, as this margin will help avoid collisions or injury.

Age Recommendation: Not for children under 14 years. This is not a toy.

- Never operate your model with low transmitter batteries.
- Always operate your model in an open area away from cars, traffic or people.
- Avoid operating your model in the street where injury or damage can occur.
- Never operate the model in the street or in populated areas for any reason.
- Carefully follow the directions and warnings for this and any optional support equipment (chargers, rechargeable battery packs, etc.) you use.
- Keep all chemicals, small parts and anything electrical out of the reach of children.
- Moisture causes damage to electronics. Avoid water exposure to all equipment not specifically designed and protected for this purpose.
- Never lick or place any portion of your model in your mouth as it could cause serious injury or even death.

FMS Kindly Reminder



Thank you for purchasing a FMS model product. Our goal is to provide high quality products and offer great customer service. If you have any problems with your product or want to offer suggestions for improvements (such as plane design, packaging, building instructions, etc.) please feel free to contact us at info@fmsmodel.com

Charge the battery

The F4U Corsair kit package may or may not contain a Li-Po Battery.

Caution: All instructions and warnings must be followed as instructed. Mishandling of Li-Po batteries can result in fire, personal injury, or property damage.

Battery Naming convention

- A battery is a collection of cells. All batteries have a naming convention which is designed to help the user identify how many cells the battery is made of and in what configuration they are. Every cell has a capacity (stored energy), measured in mAh (milliamp hours) and a voltage, measured in volts. Cells within a battery can be connected in series or parallel. Please note that all the cells must be exactly alike.
- Series connection - add the voltages of each cell together while the capacity of the whole battery remains the same as for 1 cell.
Parallel connection - add the capacities of each cell together while the voltage of the whole battery remains the same as for 1 cell.
- For example, let's say we have a bunch of 1000mAh 3.7v cells.
- If we connect 3 cells in series, the battery would be a 11.1v ($3.7v + 3.7v + 3.7v$) 1000mAh battery. If we connect 3 cells in parallel, the battery would be a 3.7v 3000mAh ($1000mAh + 1000mAh + 1000mAh$) battery.
- Now, with regard to the naming convention, the battery is named according to the following: the voltage of the whole battery, the capacity in mAh, the number of cells in series in the battery.
- The above 2 examples would be named as follows:
 - 3s1p 11.1v 1000mAh - a battery made up of 3x 1000mAh cells connected in series.
 - 1s3p 3.7v 3000mAh - a battery made up of 3x 1000mAh cells connected in parallel.
- A 14.8v 2200mAh 4s1p LiPo battery would mean that the battery is made up of 4x 2200mAh 3.7v LiPo cells connected in series.

Battery warning:

- By handling, charging or using the included Li-Po battery you assume all risks associated with lithium batteries.
- If at any time the batteries begin to swell, or balloon, discontinue use immediately! Charging or discharging a swelling or ballooning battery can result in fire.
- Always store the batteries at room temperature in a dry area to extend the life of the battery. Always transport or temporarily store the battery in a temperature range of 40-120°F. Do not store battery or model in a car or in direct sunlight. If stored in a hot car, the battery can be damaged or even catch fire.

- Never use a Ni-Mh or Ni-MH charger. Failure to charge the battery with a compatible charger may cause fire resulting in personal injury and property damage.
- Never discharge Li-Po cells to below 3V.
- Never cover warning labels with hook and loop strips.
- Never leave charging batteries unattended.
- Never charge damaged batteries.
- **Charge the in stored battery for F4U (14.8V, 25C, 2600mAh)**
Please charge your LiPo battery only on a charger specifically designed for LiPo batteries. Those chargers will have a special LiPo charging mode. There may also be just a normal charge mode, as well as a balance charge mode. Please check your LiPo before you charge it. Look for signs of swelling of the individual cells, any discolouration or if any part of the pack is warm. If your pack has any of those characteristics, please DO NOT charge or discharge it.
- Now that the naming convention has been described, please make sure of the following when charging:
 - When you plug your battery in to charge and begin charging, wait and make sure that the voltage on the display screen of the charger does not exceed whatever the pack voltage is, the voltage should not exceed 16.8v (4.2v x 4).
If the charger is capable of doing a balance charge (charging all the cells in the pack individually and at the same time), make sure that all the cells are around the same voltage
 - Always charge your battery on a non-flammable surface or in a container specially designed for charging LiPo batteries
 - If you had a 2600mAh battery, the charge rate would be 2.6A (2600/1000).
Note: Do not charge the battery over the rate we have recommended for properly prolong the life cycle of the packs.
- **LiPo battery disposal**
In order to properly dispose of a LiPo battery, you must first discharge it as low as possible. Please, if the battery has been damaged DO NOT discharge it, just proceed with the next step
Fill a bucket or some plastic container (NO METAL) with water, and add salt. Add approximately 1/4 cup of salt for every litre of water. The container may have a lid but must not be air tight
Immerse the battery in the salt water fully. Make sure that even the power connectors are submerged. Leave the battery for at least 2 weeks.
After 2 weeks, remove the battery, wrap in newspaper and dispose of in rubbish bin like normal rubbish.

The control horn installation

1. The control surface horns for the rudder and elevator are stapled to the bags containing the rudder and elevator, do not accidentally discard them.



2. Install the elevator control surface horns on the bottom of the elevator surface with the screws provided in the small plastic bag. The side of the stabilizer that contains the washer faces down, make sure to install the control horns on the opposite side. Make sure the control surface horns are facing into the right direction before installation. **Note:** The longer screws always located on the leading edge side of all the control surface.

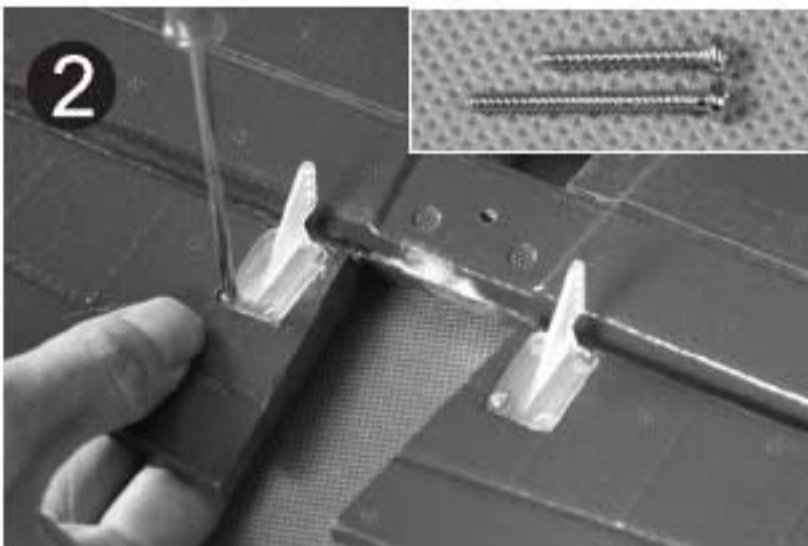

3. Always make sure that the screws are grabbing into the back plates of the control horns.

Note: It is very important that these parts are holding tight during flight.

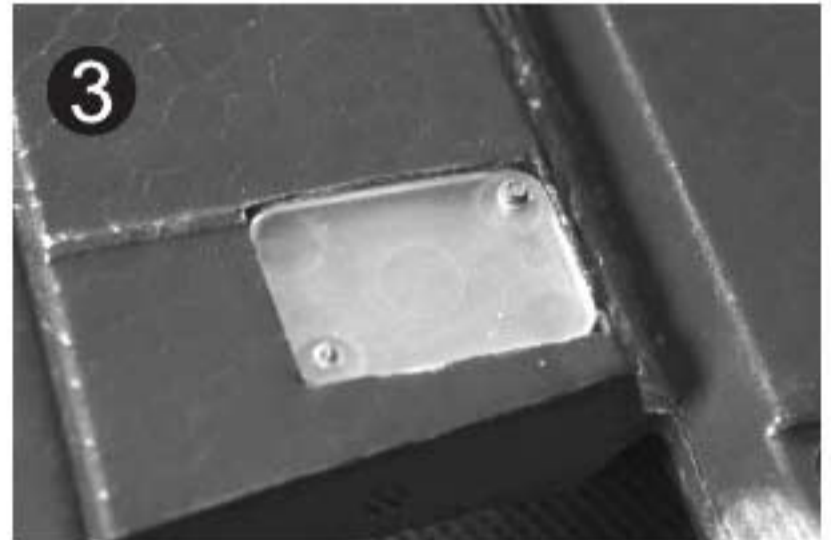

4. Attach the rudder surface control horn to the port side of the rudder.

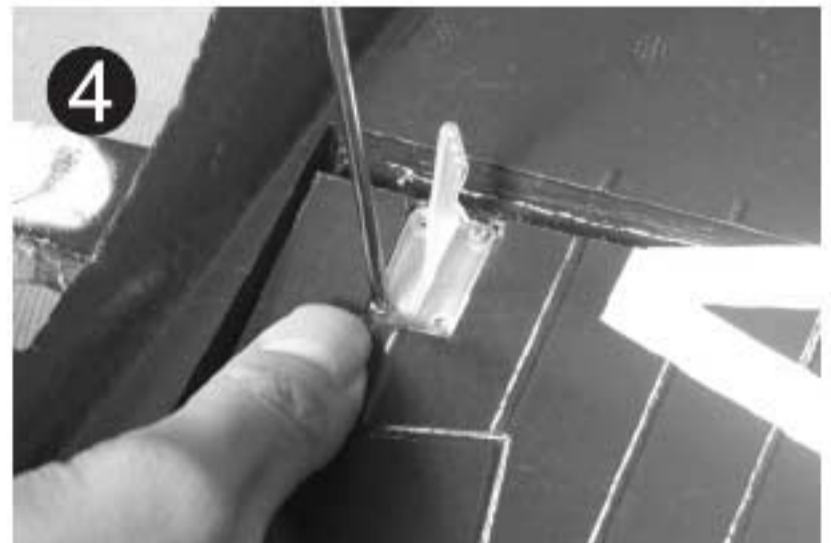

5. The aileron accessories part are include in the bag with the label "Aileron".



The control horn installation

6. Now attach the aileron surface control horns to the bottom of the lower main wing.

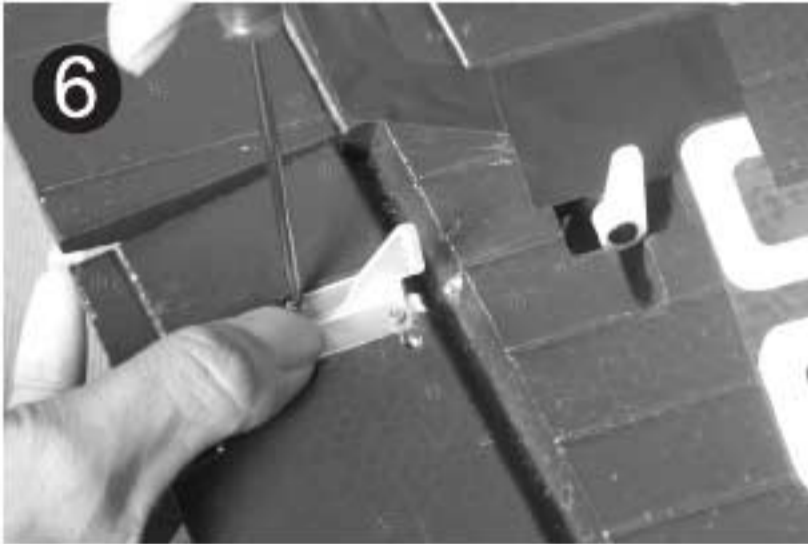

7. Attach the flaps control horn the same with the aileron .

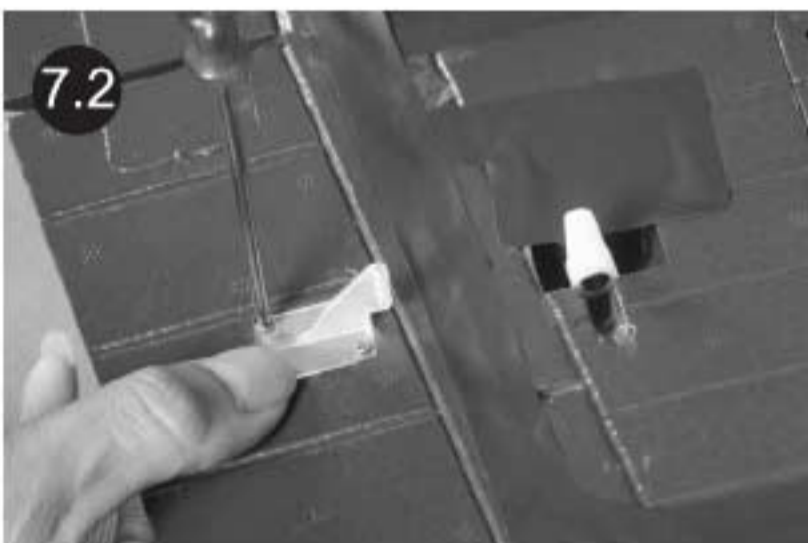

One piece main wing building

1. Insert the in stored fiberglass tube into the socket on the main wing root.
Note: When sliding the tubes into the wings, they should go in easily. Do not push them farther than they will go with little resistance. That would push the wing tubes into the foam of the wing and prevent them from fully inserting into the opposite wing half. Insert the connecting tube till the white mark the factory pre spackled.



2. Connect the rest half wing to the rods, slide it in slightly. Make sure there is no slot between this two main wing panels. If not, you have to check the obstruction out.



Test the main wing electric device

1. Before getting started, bind your receiver with your transmitter. Please refer to your **Transmitter Manual** for proper operation. **CAUTION:** To prevent personal injury, DO NOT install the propeller assembly onto the motor shaft while binding the receiver to your transmitter.
2. Connect the wing leads to the harness the first. Two ailerons servo parallel with two landing light to the four way harness labeled **AILE**, flaps and the Nav lights to the harness labeled **CH6**, main landing gears(**CH5B**) and the fairing door servos(**CH5C**) to the sequencer.
Note: Make sure the leads polarity have been correctly inserted into the socket to assure the servo and other electronic parts works properly.

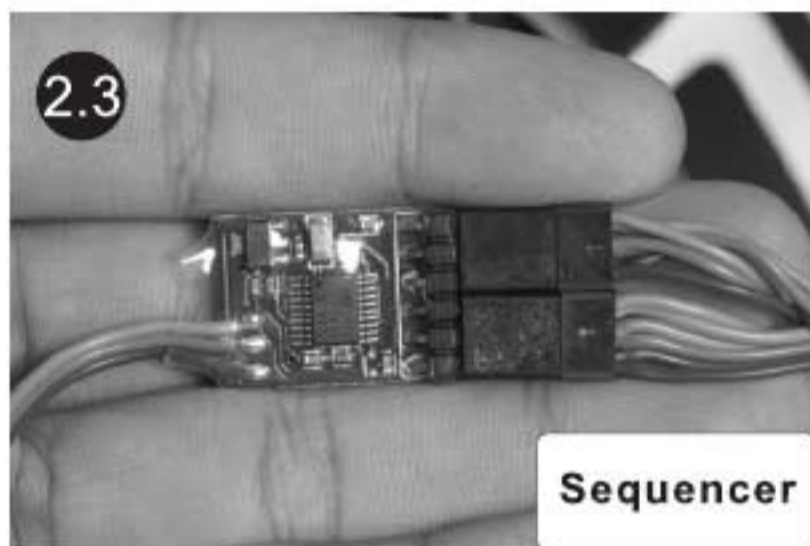
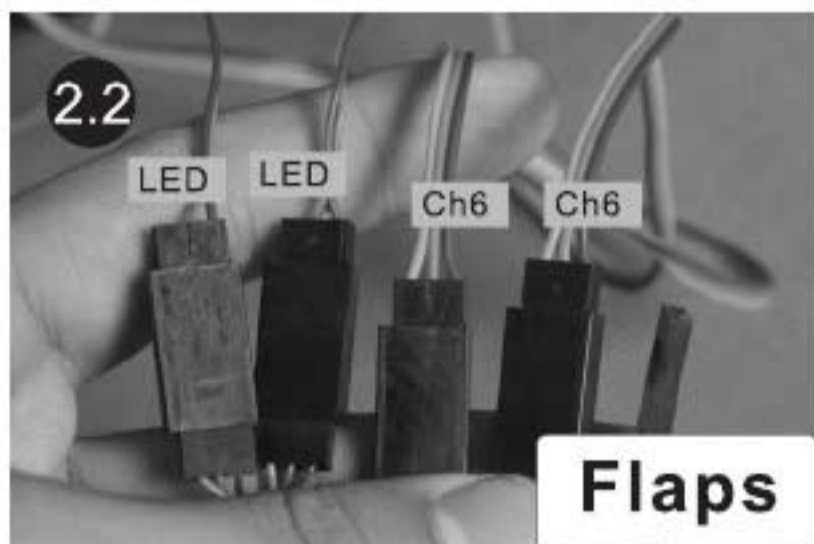
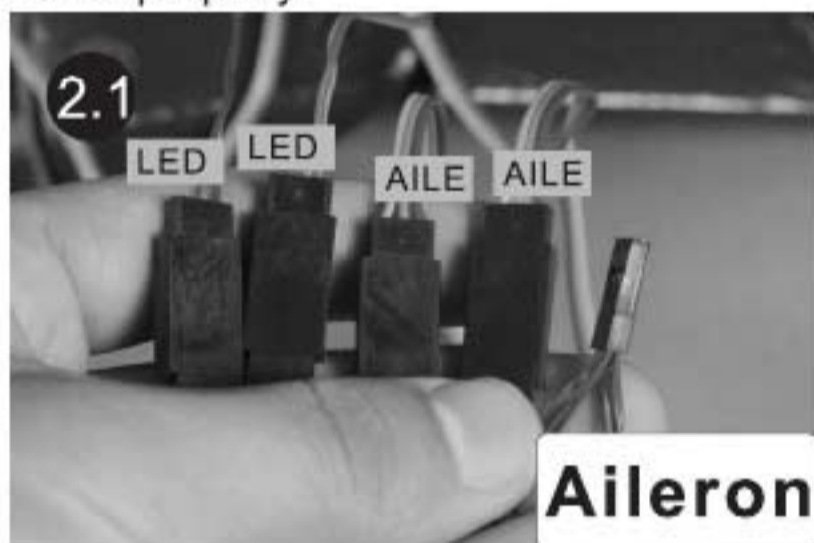

Tips: The orange and/or the white cables aligned on the same side when the cable connection completed.

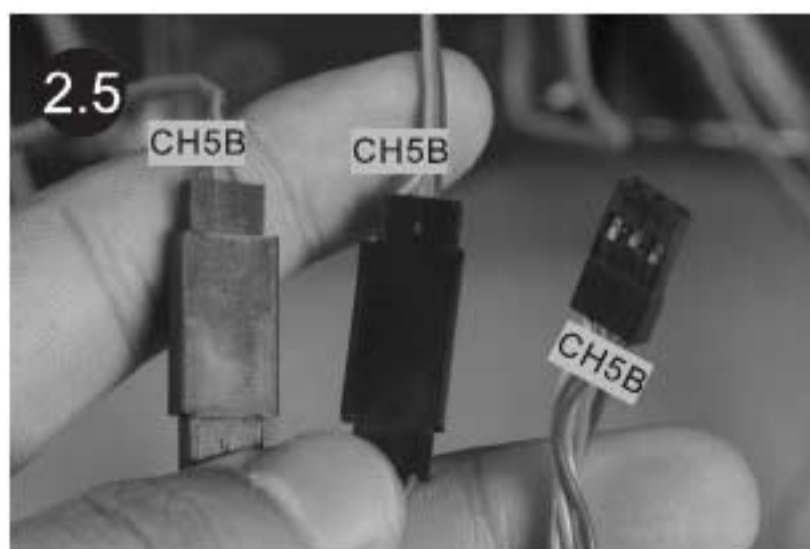
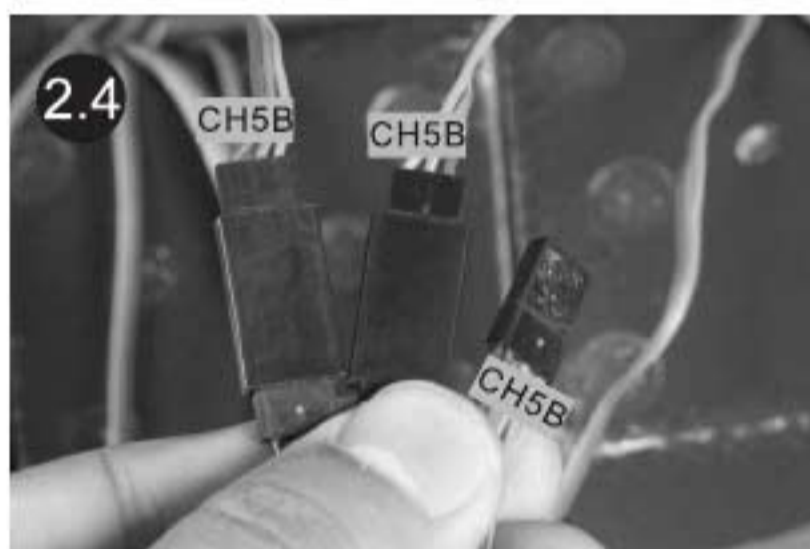

Test the main wing electric device

3. The schematic of the receiver connection

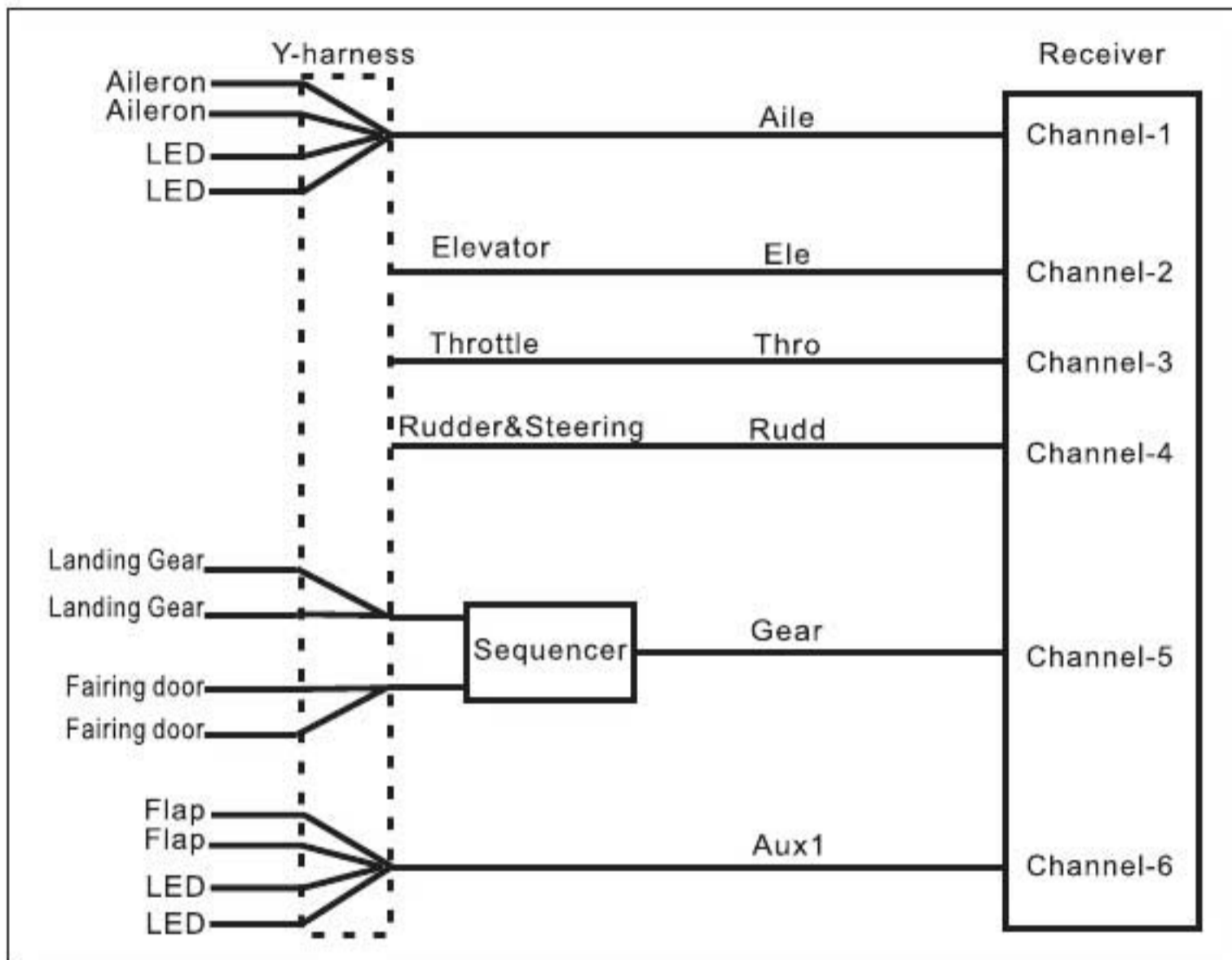

4. Diagram for the sequencer connection.

Note: With the chip side of the sequencer face up. Ch5 B for the retracts Ch5 C for fairing door driving servos. The signal wire of the leads (The orange wires) on the same side.

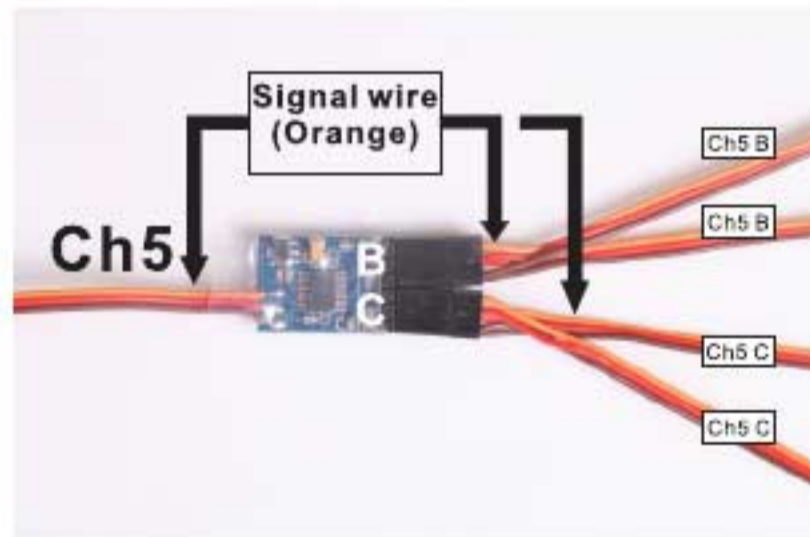

Note: All servo and retract leads have been specifically labeled for your convenience. Use the provided Y-harness for situations where two or three servos are controlled by one channel; for example ailerons, landing gear, and flaps. Refer to the diagram above for recommended connections.

Test the main wing electric device

5. Make sure the main landing gears and the faring doors work well in order, if not, you have to check that if the lead goes into the right port on the sequencer.



6. Make sure the navigation light on port side(L) wing tip emitting red beams, the starboard(R) is green. Two landing light are white.

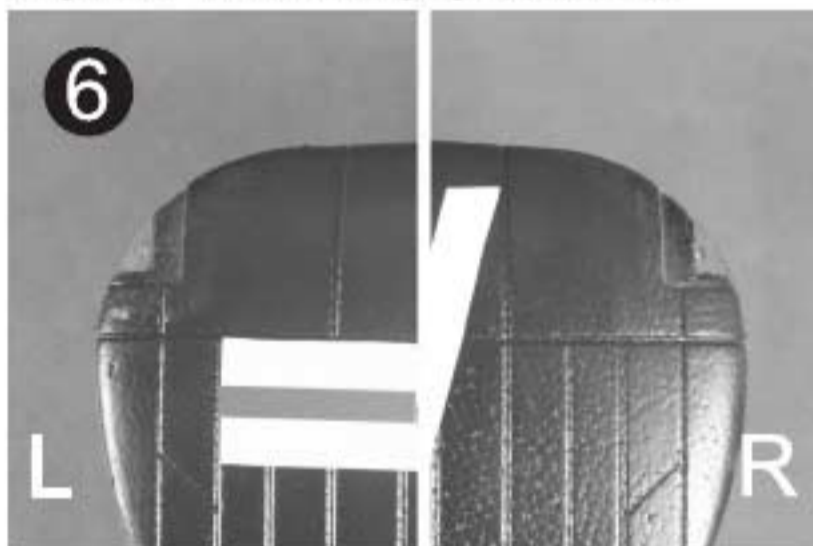

7. Stick Input the aileron to make sure the servos functions well. Put the Z-bend end of the linkage into the desired servo control horn hole of the main-wing.



8. Slap the clevis into the surface control horn.



9. The provided piece of fuel tubing keeps the clevis closed during flight. Do all the linkages the same way in the model building process.

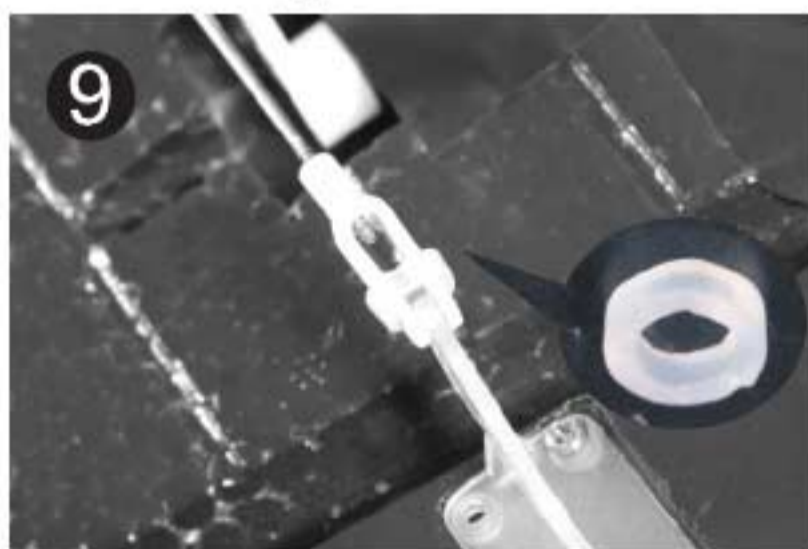

Test the main wing electric device

10. Toggle switch the flaps channel knob according to which port the Y harness you have inserted into the receiver.
Note: To avoid the "buzz" sound from the flap servos caused by the flap jam with the wing trailing edge, install either the flaps linkage while the servo arm in up position. And make sure the trailing edge of the flaps level with the wing root.



Mount the main wing

5. Mount the wing to the fuselage by fitting the foamy nose into the groove in front of the wing bay.

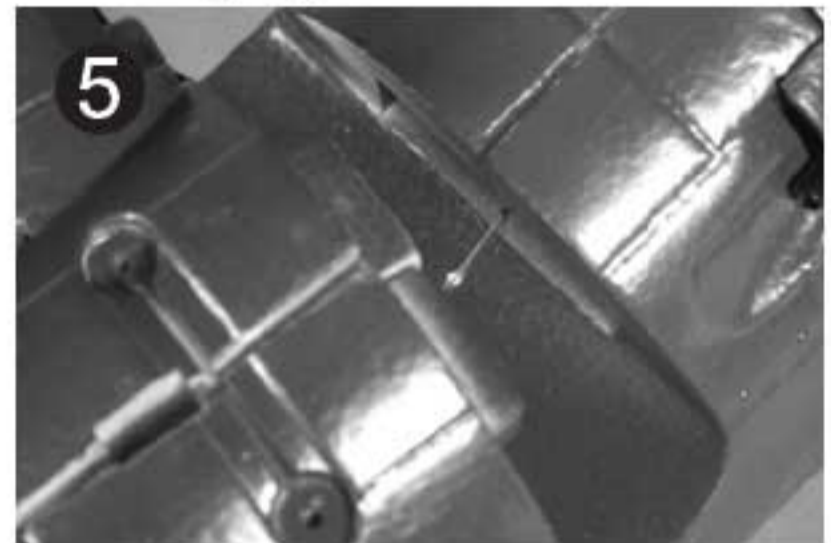

6. Guide the cables from the wing panels through the hole in the bottom of the fuselage wing bay. Put the wing into place and gently pull the cables from inside of the canopy simultaneously to avoid any tangling of the cables.

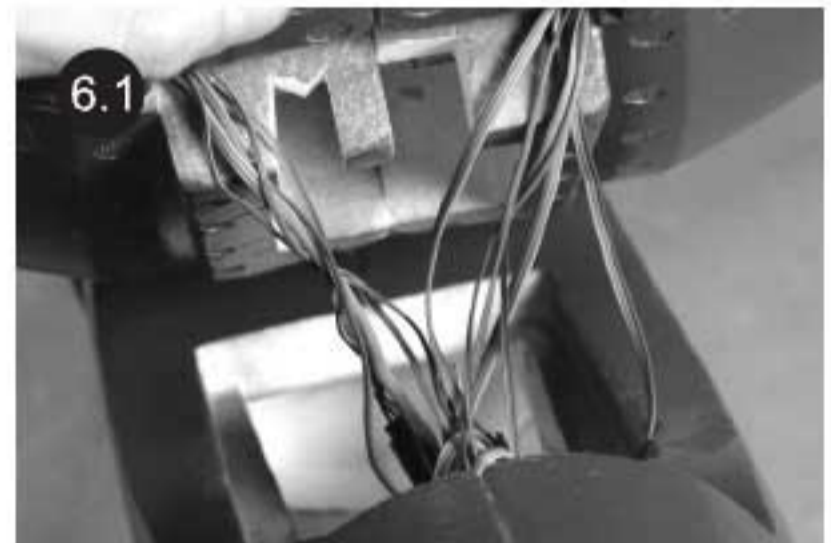

7. Fit the main wing securing plate into place.



8. Secure the main wing bolt plate using the provided machine screws.
(The rear end screws **A: PM 3.0X50 2PCS,**
B: PM 3.0X75 2PCS)

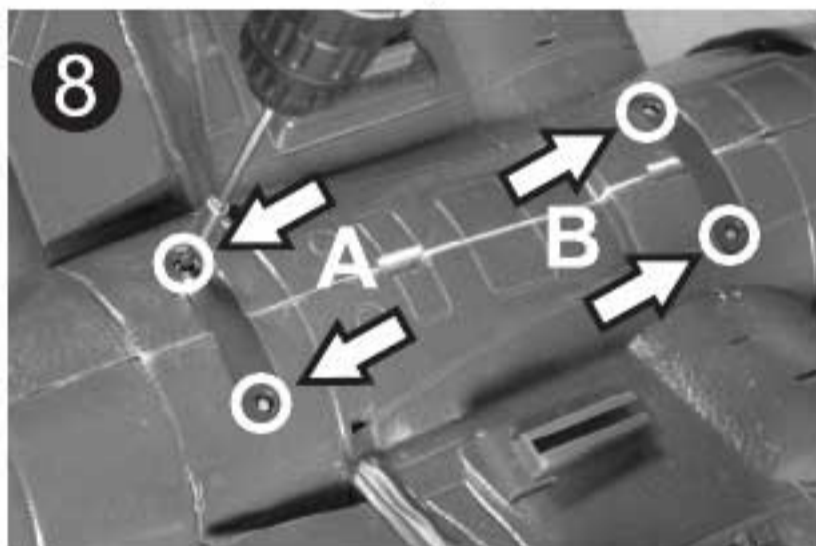

Install the stabilizer

1. Fix the horizontal stabilizer into place with the washer side face up, secure it into place using the provided self tapping screws, Make sure it fully seated into place.
(PA2.6*20 2PCS)

Note: Do not over tighten the screw, but make sure it's tight enough.

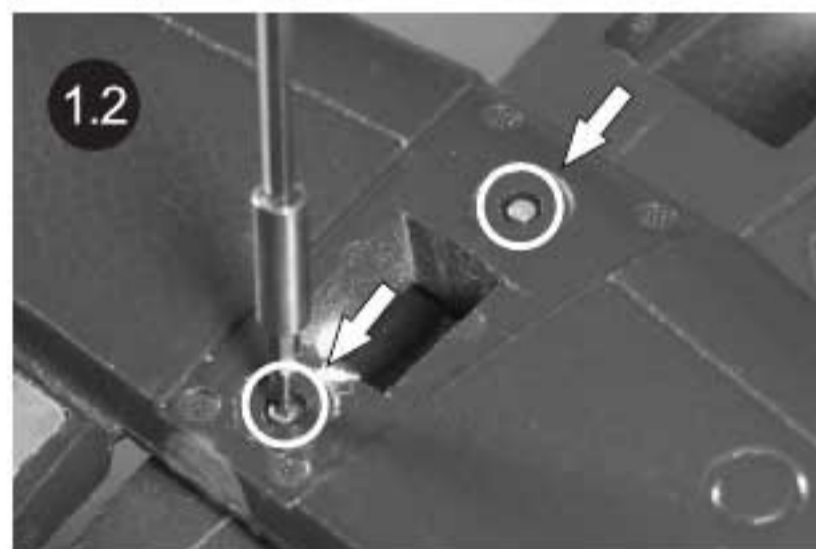

2. Insert the foamy nose in front of the vertical stabilizer into the slot as the picture shows. make sure to insert the foam nose on bottom of the vertical stabilizer into the hole on top of the horizontal stabilizer.



Disassemble the rear landing gear

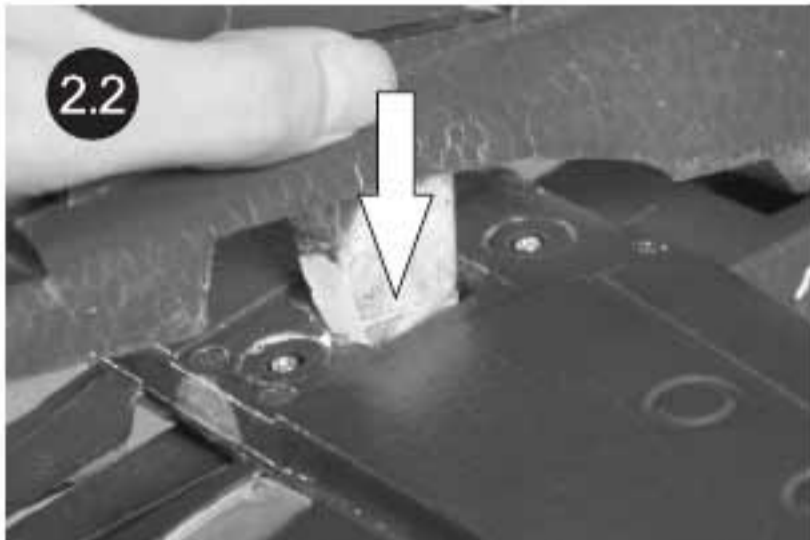

3. Turn over the plane so the bottom of the plane face up, secure the stabilizer into place using the provided self tapping screws. **(PA 2.6*25 1PCS)**
 Note: Make sure the vertical stabilizer fully fitted into place.

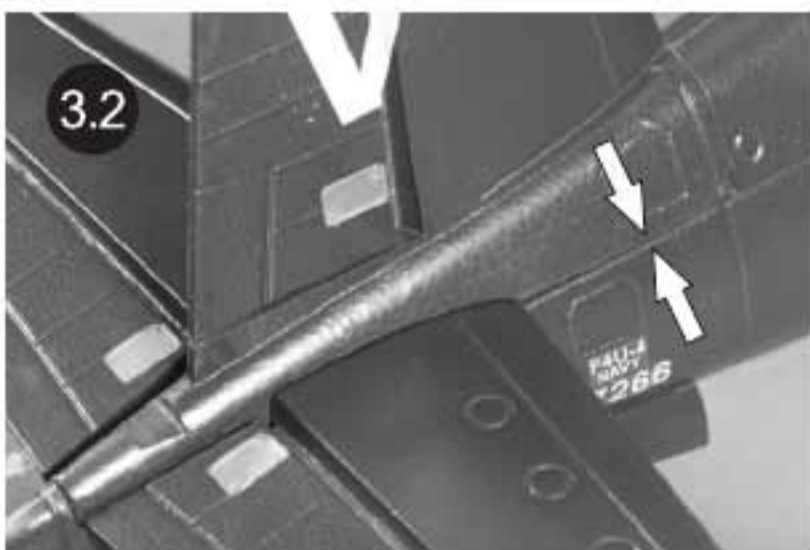

1. Unscrew the four screws that hold the gear into place.

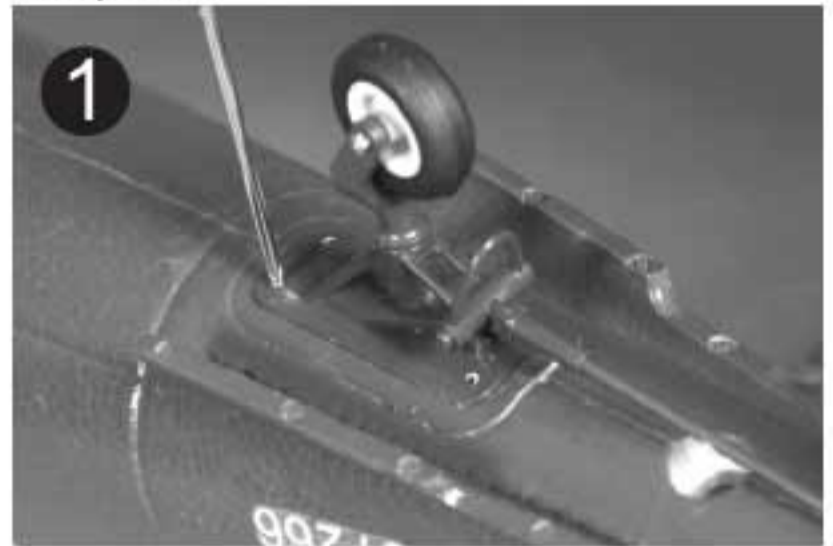

2. Pull out the assembly out a little and then slide it forward.

Note: Do not force the assembly further than it will slide,



3. Rotate the assembly counter clockwise 90 degrees and pull out the assembly.



Install the stabilizer

4. Insert the Z bend en of the linkage rod from the top of the steering arm when install the assembly. Repeat those steps in reverse to install the assembly back. Note: Be sure to insert the linkage into the control connector before fully fit the landing gear assembly into place.

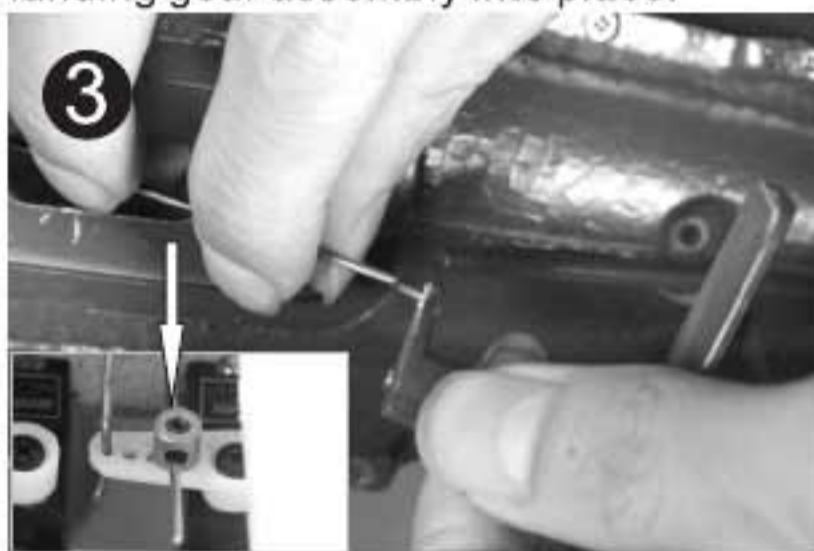

Important ESC information

1. The ESC included with the **F4U** has a safe start. If the motor battery is connected to the ESC and the throttle stick is not in the low throttle or off position, the motor will not start until the throttle stick is moved to the low throttle or off position. Once the throttle stick is moved to the low throttle or off position, the motor will emit a series of beeps. Several beeps with the same tune means the ESC has detect the cells of the battery. The count of the beeps equal the cells of the battery. The motor is now armed and will start when the throttle is moved.
2. The motor and ESC come pre-connected and the motor rotation should be correct. If for any reason the motor is rotating in the wrong direction, simply reverse two of the three motor wires to change the direction of rotation.

3. The motor has an optional brake setting. The ESC comes with the brake switched off and we recommended that the **F4U** be flown with the brake off . However, the brake could be accidentally switched on if the motor battery is connected to the ESC while the throttle stick is set at full throttle. To switch the brake off, move the throttle stick to full throttle and plug in the motor battery. The motor will beep one time. Move the throttle stick to low throttle or the off position. The motor is ready to run and the brake will be switched off.
4. Battery Selection and Installation. We recommend the 14.8V 2600mAh 25C(**270g/9.5oz**) Li-Po battery. If using another battery, the battery must be at least a 14.8V 2600mAh 25C battery. Your battery should be approximately the same capacity ,dimension and weight as the 14.8V 2600mAh 25C Li-Po battery to fit in the fuselage without changing the center of gravity significantly.
5. No beeps from the Motor, you need to calibrate the throttle or restore the factory setup defaults.

How to calibrate:

 1. Power on your Transmitter
 2. Set the Throttle stick all the way up to a 100%
 3. Power on your aircraft.
 4. Wait about 2 seconds in and you will hear 1 beep, immediately after the first beep, bring your throttle stick all the way down to 0%.
 5. You will hear a single initializing beep.
 6. Power down you Aircraft then Transmitter.
 7. Power on your Transmitter first then the Aircraft and you should be all set.

How to restore: Repeat the **How to calibrate** setting, but the restoring step holds more audible tone accounts, please refers to **ESC manual** to set the ESC, every signal means a tone in the manual. For example, the mark "*** ___ ***" means a tone. When you here the forth tone in the restore step, bring your throttle stick all the way down to 0%.

Caution: If you try to weld a new connecter 3.5 Golden plug, XT 60 or a Dean plug. Please refers to the polarity on your battery and make sure you do not weld the connector pole in reverse, or the short circuit will ruins your battery and the ESC.

The control system testing

Before getting started, plug the receiver and rebind your receiver with your transmitter is necessary according the binding status of your receiver and the transmitter.

CAUTION: To prevent personal injury, DO NOT install the propeller assembly onto the motor shaft while testing the control surfaces . DO NOT arm the ESC and do not turn on the transmitter until the **Transmitter Manual** instructs you to do so.

Tips: Make sure all control sticks on your radio are in the neutral position (rudder, elevator, ailerons) and the throttle in the OFF position. Make sure both ailerons move up and down (travel) the same amount. This model tracks well when the left and right ailerons travel the same amount in response to the control stick.

1. Move the controls on the transmitter to make sure aircraft control surface move correctly. See diagrams below. If controls respond in the opposite direction reverse the direction for operation of flight controls. Refer to your transmitter's instructions for changing direction of transmitter flight controls.

	Bank Left		Aileron
	Bank Right		
	Climb		Elevator
	Descend		
	Yaw Left		Rudder/ Steering
	Yaw Right		

The control system testing

- Adjust the servo arms mechanically make sure all servo arms are fully vertical. If not, adjust the servo arm by using the trim function on your radio.
Note: For computerized transmitters, use the servo/channel sub-trim feature to make each servo arm fully vertical. Make sure the trims and the sub trims in neutral position before making some mechanically trim.
- The standard hole settings for linkage connections are shown by the black arrows in the the diagram below. You can refer the recommended control throw setting to move the linkage to different hole positions to increase control surface travel and increase the aerobatics of the airplane. For the computerized transmitter, please refers to the **Low and High rate** setting for more accurate control throw setting.

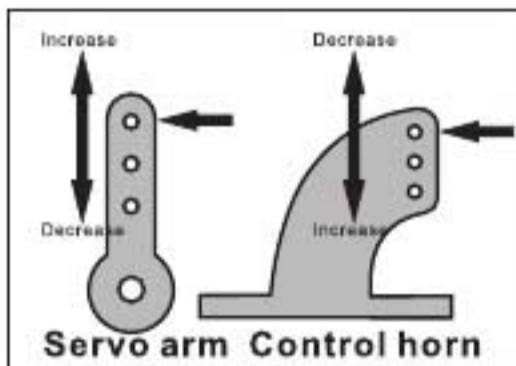

	High rate	Low rate
Elevator -	25mm/1.0in up and down	15mm/0.6in up and down
Rudder -	25mm/0.98in left and right	21mm/0.8in left and right
Ailerons -	28mm/1.1in up and down	17mm/0.7in up and down
Flaps -	Mid 22mm/0.9in Full 45mm/1.8in	

- Align the slotted flaps control surfaces well with the wing root by turning the clevis clockwise and counterclockwise on the linkage rod while the flaps in up position. The aileron align with the flaps.

Note: Secure the clevis using the securing tube after the alignment of the surface is completed.

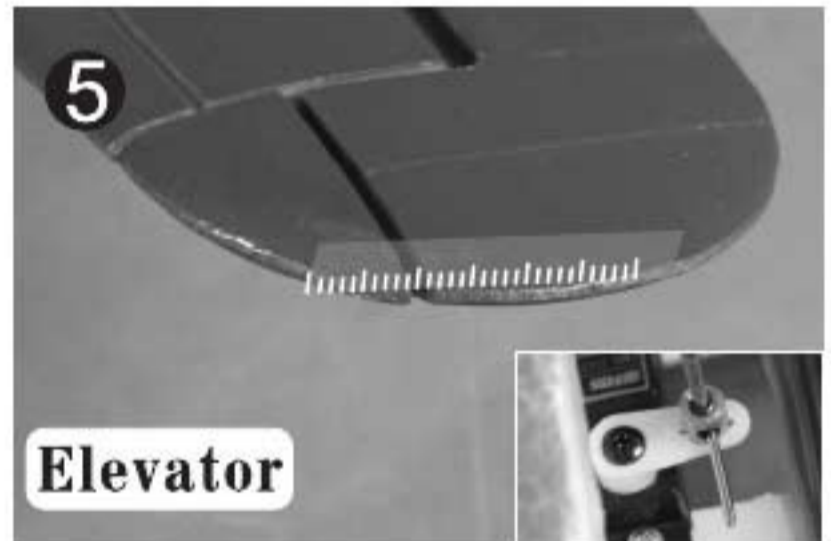

- Align the elevator control surfaces well by adjusting the linkage in the control connector. The counter balance leading edge of the elevator level with the trailing edge of the stabilizer.

Note: Use a drop of thread lock on the grub screws before securing the linkage rod.

- Align the tail wheel with the fuselage centerline by adjusting the linkage rod in the cockpit area. Repeat the **Step 4** to align the rudder with the vertical fin.



The control system testing

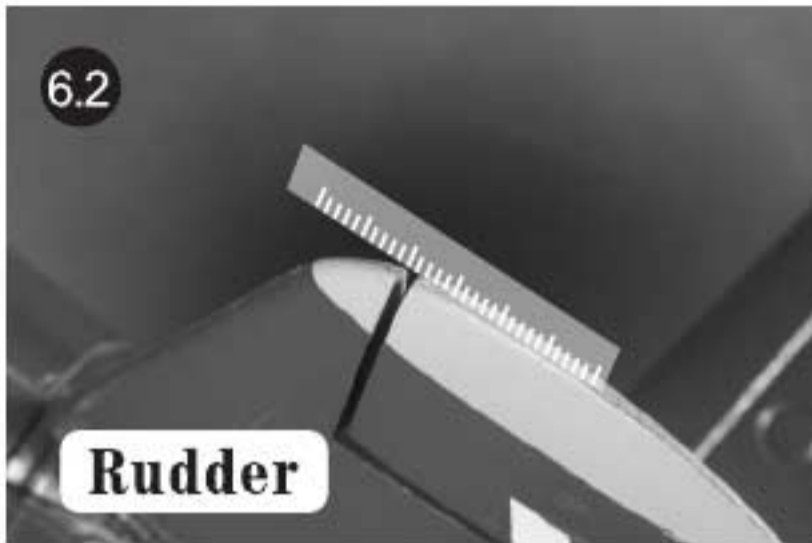

7. Test the motor make sure it is responsive to the throttle input and rotate the counter clock wise from the tail view, or you have to reset the transmitter.



Install the propeller blade

1. The propeller and the spinner kit.



2. Fit the propeller blades to the backplate of the hub with the decal side face up. **Note:** The hub center of the backplate contain a hex notch.

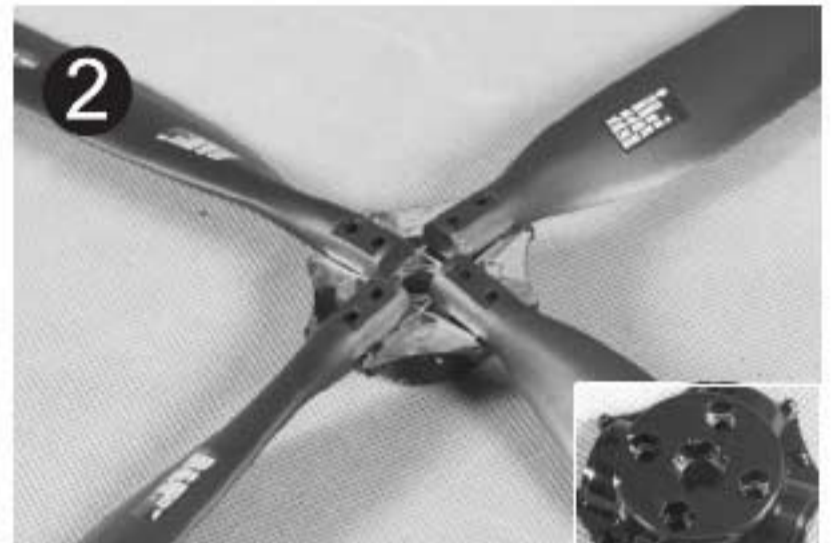

3. Place the front plate of the hub into place.



4. Snap the hub to make sure the hub halves fully hold into place.



Install the propeller assembly

CAUTION: Before testing the propeller, make sure the tail of the plane is firmly on the ground and ensure there are no people or objects in the range of the propeller. Make sure the throttle stick and the trim on the lowest position before plug in the battery.

1. Place two Nylon Insert Lock Nuts rightly into the hex notch on bottom of the spinner back plate.

Note: Always hold the nuts into place in the process of the blades mounting.



2. Secure the hub using the machine screws in stored with hub.



3. Verify the completed propeller set installation.



4. Keyed the propeller assembly to the motor shaft, make sure to fit the assembly into the hex nut on the shaft, it will help to hold the assembly in fixed position when the engine contacted.

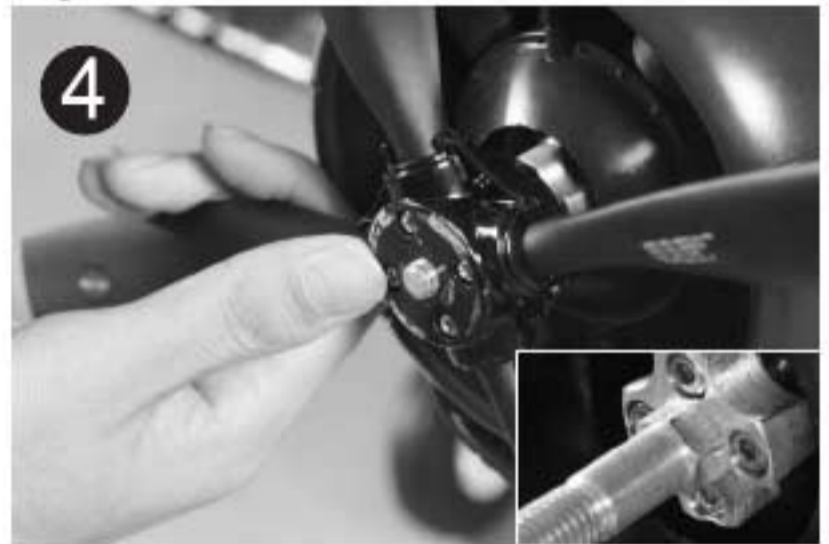

5. Hand tighten the spinner and make sure it is tight enough.



Install the accessory parts of the plane

1. Attach the receiver to the hatch in bottom of the canopy bay as the picture shows.



2. The battery position.



3. Disassemble the faring plate at the bottom of the main wing.

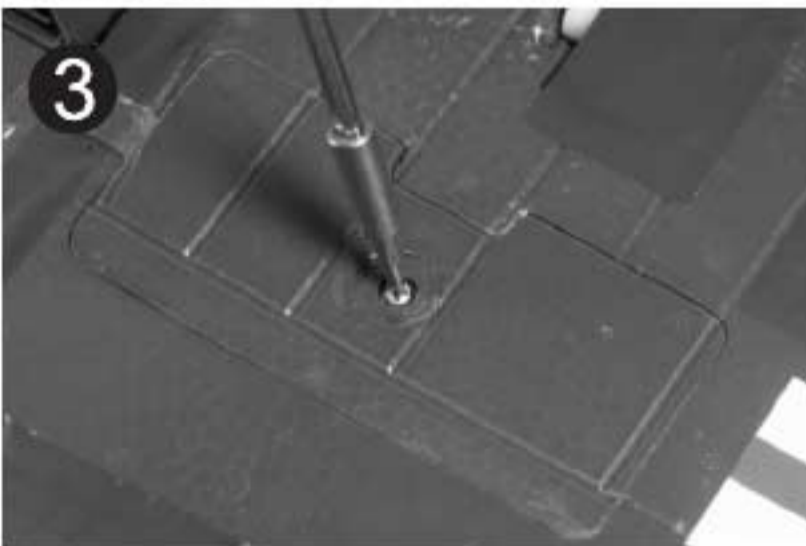

4. Rise the plate by holding the tape on one end of the plate.

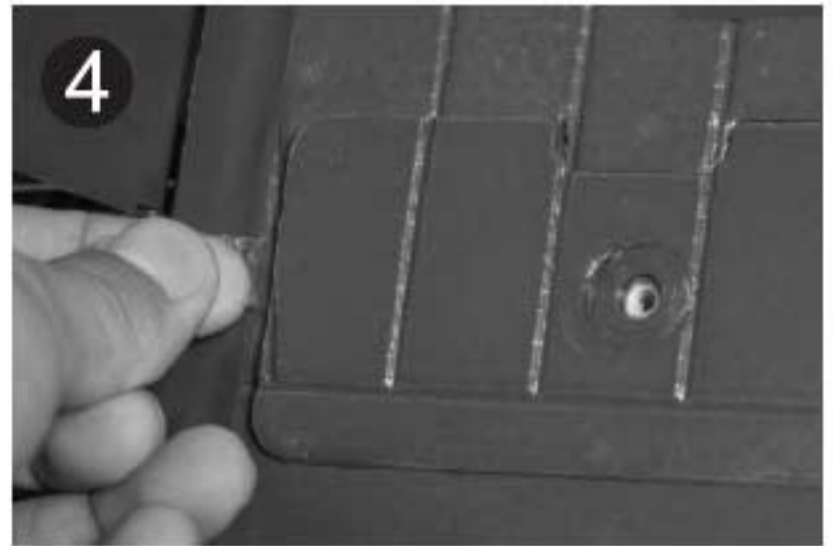

5. Install the proper rocket mounting rail into place and secure it.

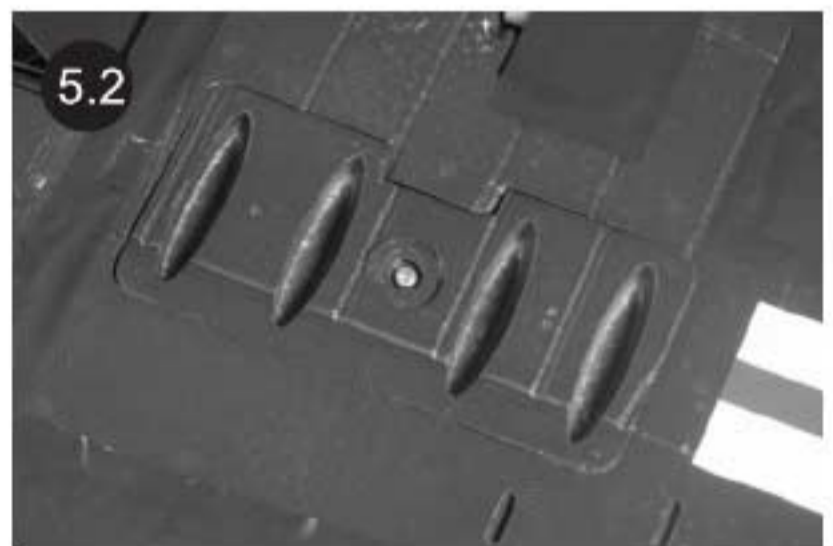
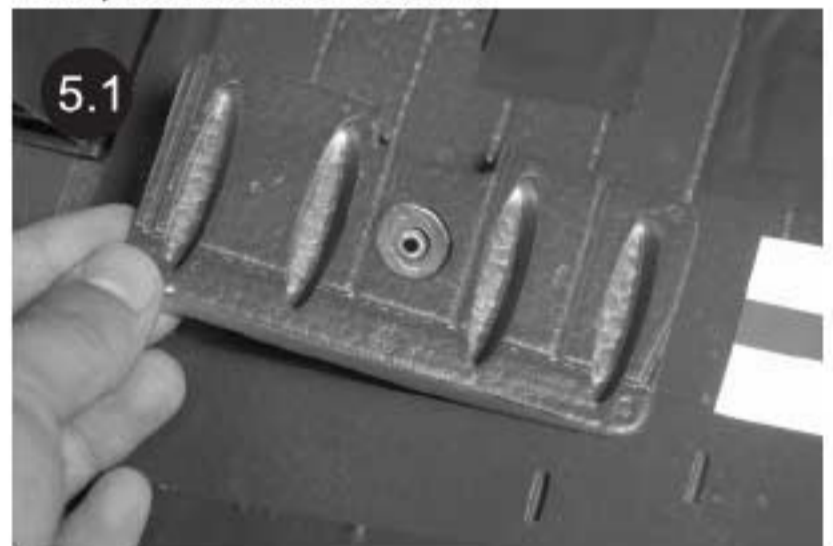

Install the accessory parts of the plane

6. Glue the rockets into place.
Tips: We do not recommended to install the rockets and the oil tanks for the aerobatic flying experience.

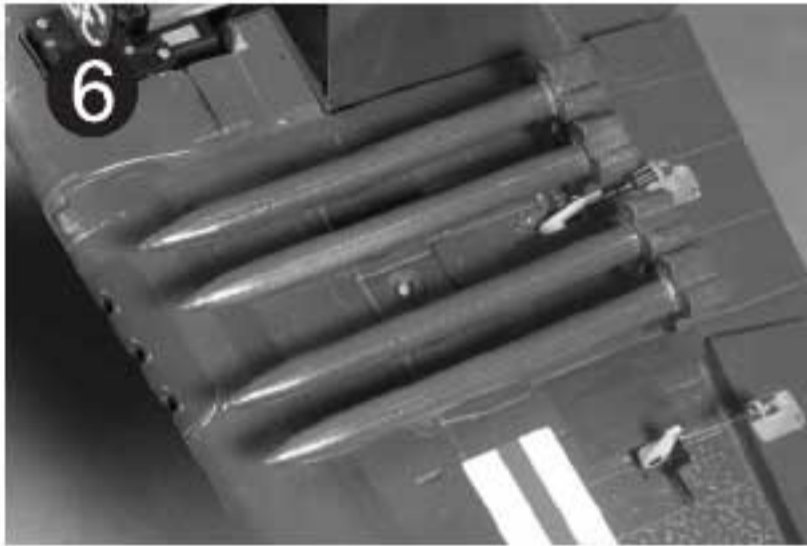

7. Slide the oil tanks into the tanks rack , two tanks are the same, you can take any one of them to hang on a rack.

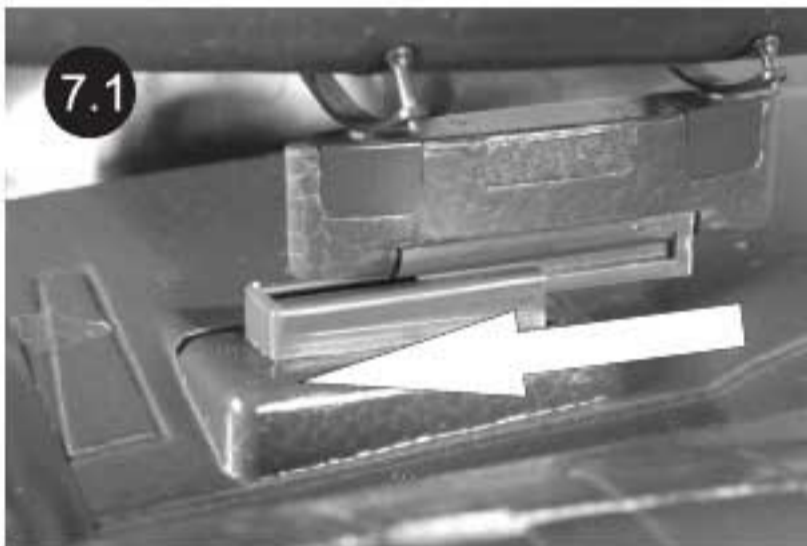

8. Glue the antenna mast into place as the picture shows.

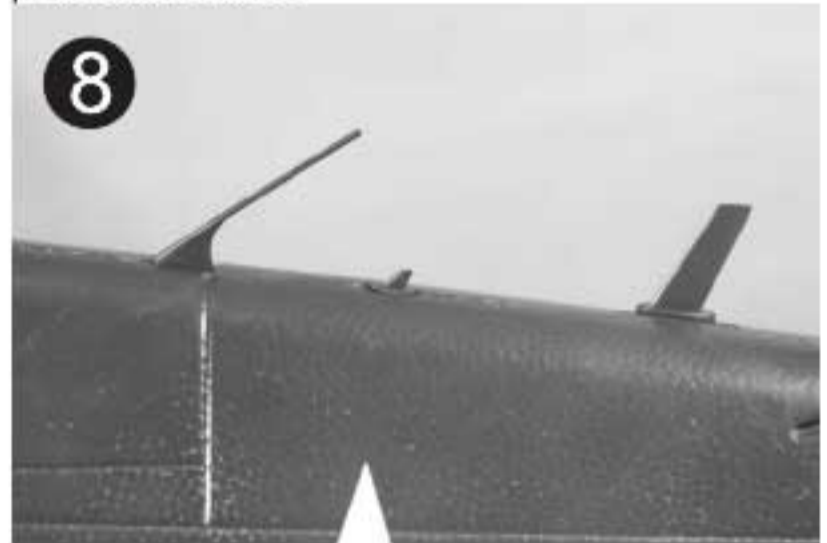

9. Glue the air speed head onto the bottom of the port side wing tip.

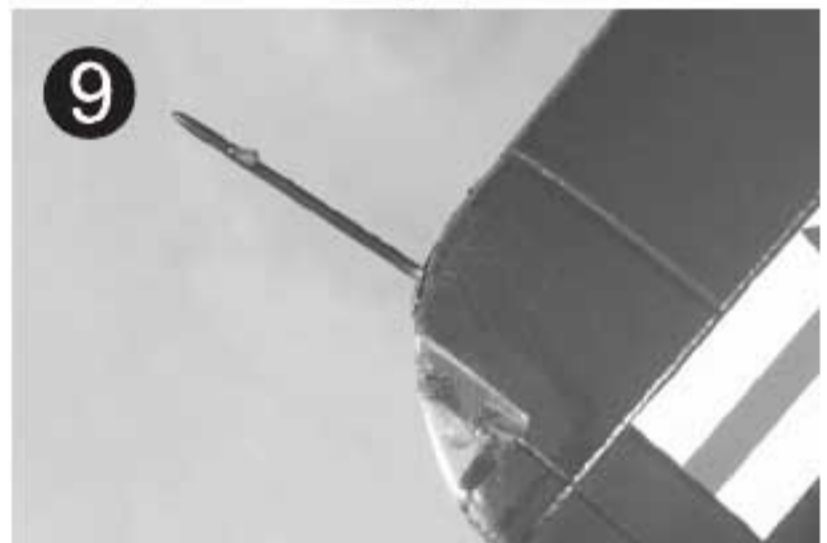

Check the C.G. (Center of Gravity)**Center of Gravity**

When balancing your model, adjust the motor battery as necessary so the model is level or slightly nose down. This is the correct balance point for your model. After the first flights, the **CG** position can be adjusted for your personal preference.

1. The recommended Center of Gravity (**CG**) location for your model is (**110mm/4.3in**) forward from the leading edge of the main wing (as shown) with the battery pack installed. Mark the location of the **CG** on top of the wing.

2. When balancing your model, support the plane at the marks made on the bottom of the main wing with your fingers or a commercially available balancing stand. This is the correct balance point for your model. Make sure the model is assembled and ready for flight before balancing.

3. Always balance the plane with the retracts down.

Caution: Do not connect the battery to the ESC while balancing the plane. Always balance the plane with the retract down.

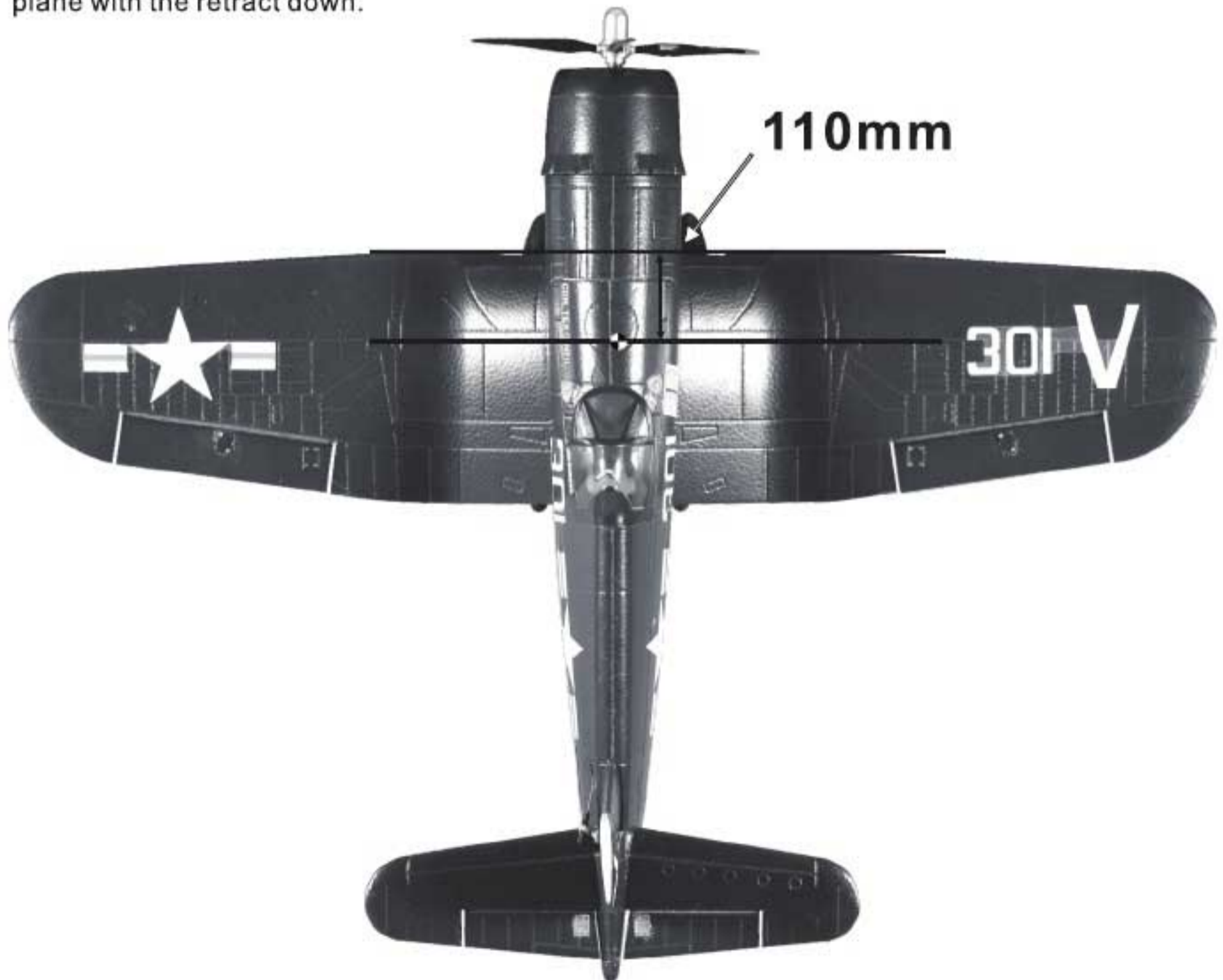

Main specification and spare parts

Specification

Wing span: 1400mm/55.6in

Length: 1240mm/49.0in

Motor : 4250-KV540

ESC : 70A with 5A SBEC

Battery : 14.8V 2600mAh 25C

Servo : 17g*6, 9g*2

Approx flying weight: 2440g

Propeller: 14*8 four blades scale propeller

Wing area: 38.7dm²

Wing loading: 63.0 g/dm²

The recommended TX &RX system: 6CH
at least

Spare parts list for F4U

Item# Description

SV-101 Fuselage

SV-102 Main wing (A pair of wing with the gear base installed)

SV-103 Vertical stabilizer

SV-104 Horizontal stabilizer

SV-105 NACA cowling part 1 (The foamy cowling)

SV-106 Cockpit (Foam cockpit hatch and Plastic canopy and Pilot)

SV-107 Oil tank (A pair of identical oil tank)

SV-108 Rocket set (8 pieces)

SV-109 Motor (4250-KV540)

SV-110 Battery (14.8V 2600mAh 25C)

SV-111 ESC (70A with 5A SBEC)

SV-112 9g servo/**Positive** (**Positive** for starboard of main landing gear doors)

SV-113 9g servo/**Reverse** (**Reverse** for port side of main landing gear doors)

SV-114 17g servo (For all the control surface: Elevator, Rudder, Ailerons, Flaps)

SV-115 Propeller (Four pieces blade)

SV-116 Sequencer (For the landing gear system)

SV-117 Main landing gear system (A pair of retracts with strut and wheel installed)

SV-118 E-Retract (A pair of electric retracts)

SV-119 Main landing gear strut (A pair of strut with tires)

SV-120 Tire set (Tricycle tire set)

SV-121 Motor board

SV-122 Spinner

SV-123 Main landing gear fairing door (A pair of main landing gear fairing door)

SV-124 NACA cowling part 2 (The plastic cowling)

SV-125 Rear landing gear system

SV-126 Motor shaft

SV-127 X motor base

SV-128 Linkage rod

SV-129 Screw set

SV-130 Decal sheet

Note: All spare parts without decals are applied.

Spare Parts List for The plane



SV-101



SV-102



SV-103

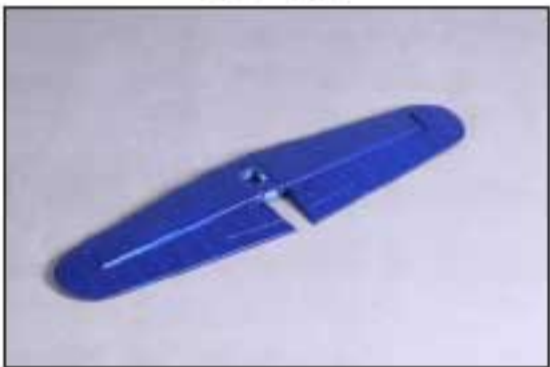

SV-104



SV-105



SV-106



SV-107



SV-108



SV-109



SV-110



SV-111



SV-112



SV-113



SV-114



SV-115

Spare Parts List for Shangri-la Scheme

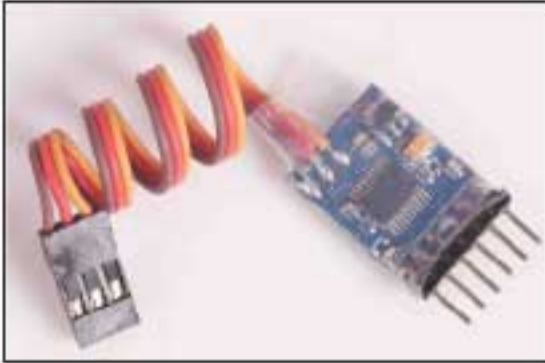

SV-116

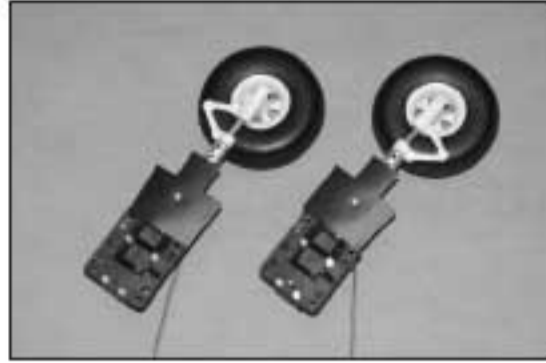

SV-117

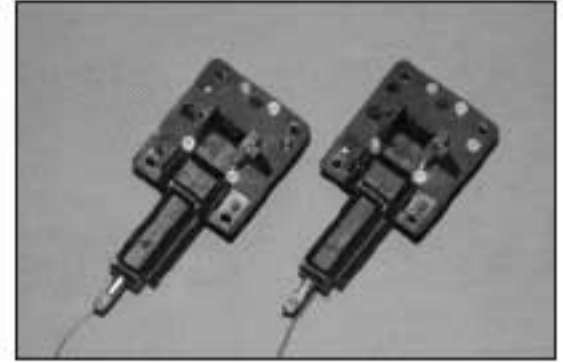

SV-118



SV-119



SV-120



SV-121



SV-122

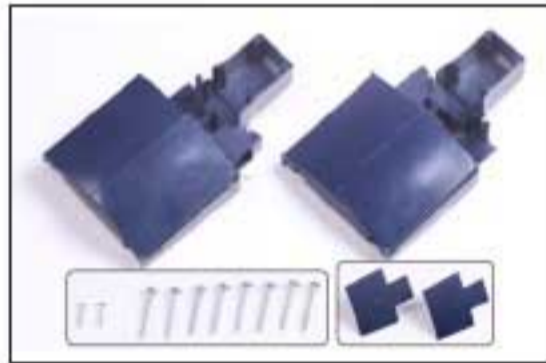

SV-123



SV-124



SV-125



SV-126



SV-127



SV-128



SV-129



SV-130

ESC instruction

Wires Connection:

The electronic speed controller can be connected to the motor by soldering directly or with high quality connectors. Always use new connectors, which should be soldered carefully to the cables and insulated with heat shrink tube. The maximum length of the battery pack wires shall be within 6 inches.

- Solder controller to the motor wires.
- Solder appropriate connectors to the battery wires.
- Insulate all solder connectors with heat shrink tubes.
- Plug the "JR" connector into the receiver throttle channel.
- Speed Controller Red and Black wires connects to battery pack Red and Black wires respectively.

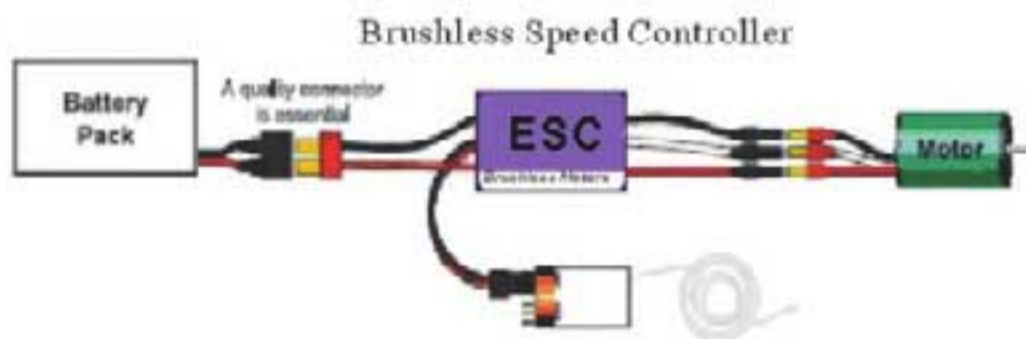

Specification:

Model #	Cont. Current(A)	Burst Current (A) 10s.	Battery cell NiXX/Lipo	Weight (g)	BEC Output	Size (mm) W*L*H	User Program
6A	6A	8A	5-10 NC \ 2-3 Lipo	5	5volts / 2amps	13 x 21 x 4	yes
12A	12A	16A	5-12 NC \ 2-4 Lipo	8	5volts / 1amps	21 x 22 x 4	yes
20A	20A	30A	5-12 NC \ 2-4 Lipo	18	5volts / 3amps	13 x 21 x 4	yes
30A	30A	40A	5-12 NC \ 2-4 Lipo	30	5volts / 3amps	23 x 43 x 6	yes
35A	35A	45A	5-12NC \ 2-4 Lipo	47	5volts / 4amps	28 x 38 x 8	yes
40A	40A	50A	5-12 NC \ 2-4 Lipo	44	5volts / 3amps	28 x 38 x 8	yes
45A	45A	55A	5-12 NC \ 2-4 Lipo	42	5volts / 3amps	31 x 58 x 11	yes
50A	50A	70A	5-18NC \ 2-6 Lipo	45	5.5volts / 5amps	31 x 58 x 11	yes
60A	60A	70A	5-12NC \ 2-4Lipo	50	5.5volts / 3amps	36 x 50 x 8	yes
65A	65A	85A	5-18NC \ 2-6Lipo	58	5.5volts / 5amps	30 x 56 x 11	yes
70A	70A	75A	5-12NC \ 2-6 Lipo	56	5.5volts / 5amps	34 x 52 x 14	yes
85A	85A	100A	5-18NC \ 2-6Lipo	63	5.5volts / 5amps	34 x 52 x 14	yes

Features:

- ◆ Extremely low internal resistance
- ◆ Super smooth and accurate throttle linearity
- ◆ Safety thermal over-load protection
- ◆ Auto throttle shut down in signal loss situation
- ◆ Supports high RPM motors
- ◆ Power arming protection (prevents the motor from accidentally running when switched ON)
- ◆ New advanced programming software

Our ESC allows you to program parameters to fit your specific needs:

Our ESC allows you to program parameters to fit your specific needs:

1. User programmable brake setting (we recommend using brake for only folding props applications)
2. User programmable battery type (LiPo or NiCd/NiMh)
3. User programmable low voltage cutoff setting
4. User programmable factory default setting restore
5. User programmable timing settings (to enhance ESC efficiency and smoothness)
6. User programmable soft acceleration start ups (for delicate gearbox and helicopter applications)
7. User programmable governor mode (for helicopter applications)
8. User programmable motor rotation (clockwise\counterclockwise)
9. User programmable switching frequency
10. User programmable low voltage cutoff type (power reduction or immediate shutdown)

Settings:

1. Brake: ON/OFF

* ON-Sets the propeller to the brake position when the throttle stick is at the minimum position (Recommended for folding props).

* OFF-Sets the propeller to freewheel when the throttle stick is at the minimum position.

2. Battery type: LiPo or NiCad/NiMh

* NiCad/NiMh – Sets Low Voltage protection threshold for NiCad/NiMh cells.

* LiPo – Sets Low voltage protection threshold for LiPo cells and automatically detects the number of cells within the pack.

Note: Selecting the NiCad/NiMh option for the battery type, triggers the ESC to automatically set the cutoff threshold to the factory default of 65%. The cutoff threshold can then be subsequently altered through the Low Voltage protection function, if required. The ESC will read the initial voltage of the NiCad/NiMh pack once it is plugged in and the voltage read will then be used as a reference for the cutoff voltage threshold.

3. Low Voltage Protection Threshold (Cutoff Threshold):

Low / Medium / High

1) For Li-xx packs- number of cells are automatically calculated and requires no user input apart from defining the battery type. This ESC provides 3 setting options for the low voltage protection threshold; Low (2.8V)/ Medium (3.0V)/ High (3.2V). For example: the voltage cutoff options for an 11.1V/ 3 cell Li-Po pack would be 8.4V (Low)/ 9.0V (Med)/ 9.6V (High)

2) For Ni-xx packs-low / medium / high cutoff voltages are 50%/65%/65% of the initial voltage of the battery pack. For example: A fully charged 6 cell NiMh pack's voltage is $1.44V \times 6 = 8.64V$, when "LOW" cutoff voltage is set, the cutoff voltage is: $8.64V \times 50\% = 4.3V$ and when "Medium" or "High" is set, the cutoff voltage is now $8.64V \times 65\% = 5.61V$.

4. Restore factory setup defaults:

Restore - Sets the ESC back to factory default settings;

Brake :	Off
Battery type Detect :	LiPo with Automatic Cell
Low voltage cutoff threshold :	Medium (3.0V/65%)
Timing setup :	Automatic
Soft Acceleration Start Up :	Medium
Governor mode :	OFF
Frequency :	16kHz
Low voltage cutoff type :	Reduce power

5. Timing setup: Automatic / Low / High.

- * Automatic – ESC automatically determines the optimum motor timing
- * Low (7-22 deg) – Setting for most 2 pole motors.
- * High (22-30 deg)-setting for motors with 6 or more poles.

In most cases, automatic timing works well for all types of motors. However for high efficiency we recommend the Low timing setting for 2 pole motors (general in-runners) and high timing for 6 poles and above (general outrunners). For higher speed, High timing can be set. Some motors require different timing setups therefore we suggest you follow the manufacturer recommended setup or use the automatic timing setting if you are unsure.

Note: Run your motor on the ground first after making any changes to your motor timing!

6. Soft Acceleration Start ups: Very Soft / Soft Acceleration/ Start Acceleration

- * Very Soft – Provides initial slow 1.5 sec ramp-up from start to full rpm intended to protect delicate gears from stripping under instant load. This setting is recommended for either fixed wing models equipped with gearboxes and / or helicopters.
- * Soft Acceleration- Provides initial slow 1 sec ramp-up from start to full rpm. This setting is recommended for either fixed wing models equipped with gearboxes and or helicopters.
- * Start Acceleration – Provides quick acceleration start ups with a linear throttle response. This is recommended for fixed wing models fitted with direct drive setups.

7. Active RPM Control (Heli Governor Mode)

- * RPM control off

* **First range:** There will be a 5-second delay from start to full rpm, but if the throttle is cutoff after starting, then the next start will be as normal start.

* **Second range:** There will be a 15-second delay from start to full rpm, but if the throttle is cutoff after starting, then the next start will be as normal start.

Note: Once the Governor Mode is enabled, the ESC's Brake and Low Voltage Cutoff Type settings will automatically be reset to No Brake and Reduce Power respectively regardless of what settings they were previously set.

8. Motor Rotation: Reverse

In most cases motor rotation is usually reversed by swapping two motor wires. However, in cases where the motor cables have been directly soldered to the ESC cables, motor rotation can be reversed by changing the value of setting on the ESC.

9. Switching Frequency: 8 kHz/16kHz

- * 8 kHz – Sets ESC switching frequency for 2 pole motors, e.g. in-runners.
- * 16 kHz – Sets ESC switching frequency for motors with more than 2 poles, e.g. out-runners.

Although 16 kHz is more efficient without Thrust motors, the setup default is 8 kHz due to the higher RF noises caused at 16 kHz.

10. Low Voltage Cutoff Type: Reduce Power / Hard cutoff

- * Reduce Power – ESC reduces motor power when the pre-set (recommended).
- * Hard Cutoff – ESC instantly cuts motor power when the pre-set Low Voltage Protection Threshold value is reached.

Programming Mode Audible Tones

Programming Mode Audible Tones	ESC Functions
0 Throttle Calibration (within the first 4 Sec) ● ● ● ●	

1	Brake * * * *	Brake On /Off
2	Battery type ~ ~ ~ ~ ~ ~ ~ ~	NiCad LiPo
3	Low Voltage Cutoff Threshold *	Low 2.8V/50% Medium 3.0V/60% High 3.2V/65%
4	Restore Factory Setup Defaults - - - -	Restore
5	Timing Setup - - - - - - - - - - - -	Automatic (7-30°) Low (7-22°) High (22-30°)
6	Soft Acceleration Start Ups ∨	Very Soft Soft Acceleration Start Acceleration
7	Governor Mode * * * * ** ** ** ** *** *** *** ***	Rpm off Heli first range Heli second range
8	Motor Rotation W W W W	Positive/Reverse
9	Switching Frequency // // // // \\ \\ \\ \\	8kHz 16kHz
10	Low Voltage Cutoff Type ⊗ ⊗ ⊗ ⊗ ⊗ ⊗ ⊗ ⊗	Reduce Power Hard Cut Off

Using Your New ESC

Improper polarity or short circuit will damage the ESC therefore it is your responsibility to double check all plugs for proper polarity and firm fit BEFORE connecting the battery pack.

Alert Tones

The ESC is equipped with audible alert tones to indicate abnormal conditions at power up.

If the ESC can't enter into working mode after powering up, it indicates that you have not setup throttle calibration.

1. Continuous beeping tone (****) – Indicates that the throttle stick is not in the minimum position.
2. Single beeping tone followed by a one second pause (* * * *) – Indicates that the battery pack voltage is not within the acceptable range. (The ESC automatically checks and verifies the battery voltage once the battery is connected).
3. A single beeping tone followed by a short pause (* * * *) – Indicates that the ESC is unable to detect the normal throttle signal from the receiver.

Built-in Intelligent ESC Safety Functions

1. Over-heat protection: When the temperature of ESC exceeds 110 deg C, the ESC will reduce the output power to allow it to cool.
2. Lost Throttle signal protection: The ESC will automatically reduce output power to the motor when it detects a lost

of throttle signal for 2 second, a subsequent loss of throttle signal beyond 2 seconds, will cause the ESC automatically to cut power to the motor.

Powering up the ESC for the first time and setting the Automatic Throttle Calibration

The ZTW ESC features Automatic Throttle Calibration to attain the smoothest throttle response and resolution throughout the entire throttle range of your transmitter. This step is done once to allow the ESC to “learn and memorize” your Transmitter’s throttle output signals and only repeated if you change your transmitter.

1. Switch your Transmitter ON and set the throttle stick to its maximum position.
2. Connect the battery pack to the ESC. Wait for about 2 seconds, the motor will beep for twice, then put the throttle in the minimum position, the motor will also beep, which indicates that your ESC has got the signal range of the throttle from your transmitter.

The throttle is now calibrated and your ESC is ready for operation.

Normal ESC start up procedure:

1. Switch your Transmitter ON and set the throttle to its minimum position.
2. Connect the battery pack to the ESC.
3. When the ESC is first powered up, it emits two sets of audible tones in succession indicating the status of its programming state.
 - * The first set of tones denotes the number of cells in the LiPo pack connected to the ESC. (Three beeps (***) indicates a 3 cell LiPo pack while 4 beeps (****) indicates a 4 cell LiPo pack).
 - * The second set denoting Brake status. One beep (*) for Brake “ON” and two beeps (**) for Brake “OFF” .
 - * The ESC is now ready for use.

Entering the Programming Mode:

1. Switch your Transmitter ON and set the throttle to its maximum position.
2. Connect the battery pack to the ESC.
3. Wait until you hear two short beeps (_ **) confirming that the ESC has now entered the programming mode.
4. If within 5 seconds, the throttle stick is lowered to its minimum position, an audible tone is emitted confirming that the **throttle calibration** setting has changed. If the throttle stick is left in the maximum position beyond 5 seconds, the ESC will begin the sequence from one function and its associated setting options to another. (Please refer to the table below to cross reference the functions with the audible tones).
5. When the desired tone for the function and setting option is reached, move the throttle stick down to its minimum position. ESC will emit two beeps (**) confirming the new setting has been stored.
6. The ESC only allows the setting of one function at a time. Therefore should you require making changes to other function disconnect the battery pack and wait 5 seconds to reconnect the battery and repeat the above steps.

General Safety Precautions

Do not install the propeller (fixed wing) or drive pinion (helicopter) on the motor when you test the ESC and motor for the first time to verify the correct settings on your radio. Only install your propeller or pinion after you have confirmed that the settings on your radio is correct.

- Never use ruptured or punctured battery cells.
- Never use battery packs that are known to overheat.
- Never short circuit battery or motor terminals.
- Always use proper insulation material for cable insulation.
- Always use proper cable connectors.
- Do not exceed the number of cells or servos specified by the ESC.

Wrong battery polarity will damage the ESC and void the warranty.

- Install the ESC in a suitable location with adequate ventilation for cooling. This ESC has a built-in over heat cutoff protection feature that will immediately cut power to the motor once the ESC temperature exceeds the 230 Deg F/ 110 Deg C high temperature limit.
- Use only batteries that are supported by the ESC and ensure the correct polarity before connecting.
- Switch your Transmitter ON and ensure the throttle stick is in the minimum position before connecting the battery

pack.

- Never switch your transmitter **OFF** while the battery is connected to your ESC.
- Only connect your battery pack just before flying and do not leave your battery pack connected after flying.
- Handle your model with extreme care once the battery pack is connected and keep away from the propeller at all times. Never stand in-line or directly in front of any rotating parts.
- Do not immerse the ESC underwater while powered up.
- Do fly at a designated flying site and abide by the rules and guidelines set by your flying club.

Troubleshooting:

Issue	Possible Reason	Action
Motor doesn't work, but there are audible tones of automatically detection of the number of cells after powering up ESC.	The ESC throttle calibration has not set up.	Set up the ESC throttle calibration.
Motor doesn't work and no audible tone emitted after connecting the battery. Servos are not working either.	Poor/loose Connection between battery Pack and ESC.	Clean connector terminals or replace connector.
	No power	Replace with a freshly charged battery pack
	Poor soldered connections (dry joints)	Re-solder the cable connections
	Wrong battery cable polarity	Check and verify cable polarity
	ESC throttle cable connected to receiver in the reverse polarity	Check the ESC cable connected to the ESC to ensure the connectors are in the correct polarity.
	Faulty ESC	Replace ESC
Motor doesn't work and no audible tone emitted after connecting the battery BUT servos are working.	Poor / loose connection between ESC and motor	Clean connector terminals or replace connectors
	Burnt motor coils	Replace motor
Motor doesn't work after powering up the ESC. An alert tone with two beeping tones followed by a short pause (** ** ** **) is emitted.	Poor soldered connections(dry joints) The battery pack voltage is not within the acceptable range.	Re-solder the cable connections Replace with a freshly charged battery pack Check battery pack voltage
Motor doesn't work after powering up the ESC. An alert tone with a single beeping tone followed by a short pause (** ** *) is emitted.	The ESC is unable to detect the normal throttle signal from the receiver	Check and verify that the ESC cable is connected to the <u>Throttle</u> channel on the receiver. Check the transmitter and receiver to verify that there is throttle signal output. (Connect a spare servo to verify throttle channel operation)
Motor doesn't work after powering up the ESC .An alert tone with continuous beeping tones (****) is emitted.	The throttle stick is not in the <u>minimum</u> position at power up.	Move the throttle stick to the minimum position.
Motor doesn't work after powering up the ESC. ESC emits two long audible tones followed by two short beeps(_ _ **)	Reversed throttle channel caused the ESC to enter the programming mode.	Enter the servo reverse menu on your transmitter and reverse the throttle channel. Note: For Futaba radios set the throttle channel to Reverse.

Issue	Possible Reason	Action
Motor runs in reverse rotation Motor stops running in flight.	Wrong cables polarity between the ESC and the motor.	Swap any two of the three cable connections between the ESC and the Motor or __ access the Motor Rotation function via the ESC programming mode and change the pre-set parameters.
	Lost throttle signal	Check proper operation of the radio equipment. Check the placement of the ESC and the Receiver and check the route of the receiver's aerial and ESC cables to ensure there is adequate separation to prevent RF interference. Install a ferrite ring on the ESC's throttle cable.
	Battery Pack voltage has reached the Low Voltage Protection threshold.	Land the model immediately and replace the battery pack.
	Possible bad cable connection	Check and verify the integrity of the cable connections
Motor restarts abnormally ESC Overheats	Possible RF Interference at the flying field.	The normal operation of the ESC may be susceptible to surrounding RF interference. Restart the ESC to resume normal operation on the ground to verify recurrence. If the problem persists, test the operation of the ESC at a different flying field.
	Inadequate Ventilation	Relocate the ESC to allow better ventilation
	Servos drawing too much current and over loading the ESC.	Use servos that are adequately sized for the ESC. The maximum BEC current drawn should be within the BEC limits.
	Over sized motor or prop	Prop down or resize the motor

Important Notice

Caution: A 5S LiPo battery greatly exceeds the maximum capacity of the ESC and motor and will result in ESC failure during flight. The 5S battery will cause a complete loss of control creating a potentially dangerous condition. Please do not use a 5S (18.5V) or larger battery in this product.



[Http:// www.fmsmodel.com](http://www.fmsmodel.com)
Email: info@fmsmodel.com