

RTR
READY-TO-RUN

EIGHT MINI™

1/14-SCALE BRUSHLESS TRUGGY

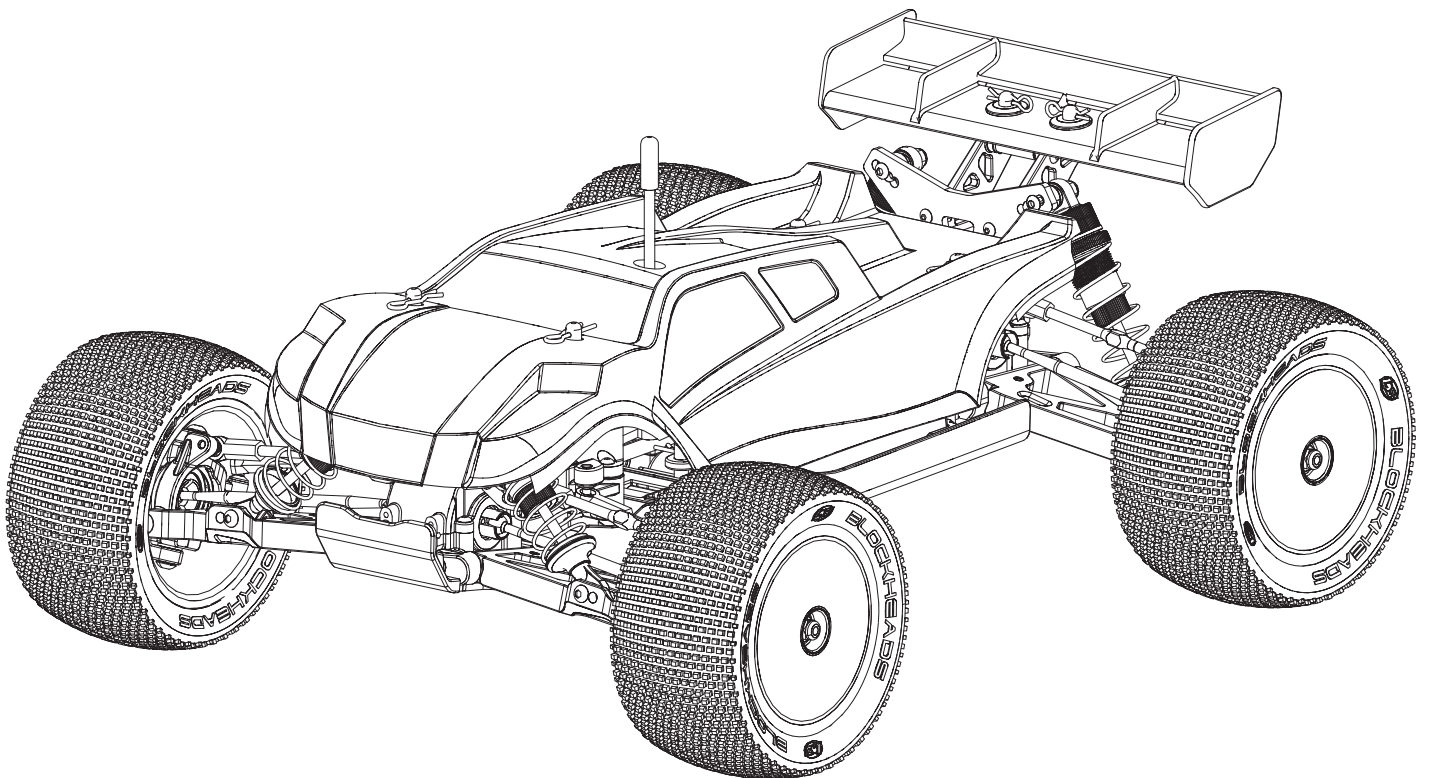

INSTRUCTION MANUAL
BEDIENUNGSANLEITUNG
MANUEL D'UTILISATION
MANUALE DI ISTRUZIONI



Before operating this vehicle, please read all printed materials thoroughly.
Horizon Hobby is not responsible for inadvertent errors in this manual.

NOTICE

All instructions, warranties and other collateral documents are subject to change at the sole discretion of Horizon Hobby, LLC. For up-to-date product literature, visit horizonhobby.com and click on the support tab for this product.

MEANING OF SPECIAL LANGUAGE

The following terms are used throughout the product literature to indicate various levels of potential harm when operating this product:

NOTICE: Procedures, which if not properly followed, create a possibility of physical property damage AND a little or no possibility of injury.

CAUTION: Procedures, which if not properly followed, create the probability of physical property damage AND a possibility of serious injury.

WARNING: Procedures, which if not properly followed, create the probability of property damage, collateral damage, and serious injury OR create a high probability of superficial injury.

 **WARNING:** Read the ENTIRE instruction manual to become familiar with the features of the product before operating. Failure to operate the product correctly can result in damage to the product, personal property and cause serious injury.

This is a sophisticated hobby product. It must be operated with caution and common sense and requires some basic mechanical ability. Failure to operate this Product in a safe and responsible manner could result in injury or damage to the product or other property. This product is not intended for use by children without direct adult supervision. Do not use with incompatible components or alter this product in any way outside of the instructions provided by Horizon Hobby, LLC. This manual contains instructions for

safety, operation and maintenance. It is essential to read and follow all the instructions and warnings in the manual, prior to assembly, setup or use, in order to operate correctly and avoid damage or serious injury.

WARNING AGAINST COUNTERFEIT PRODUCTS

Always purchase from a Horizon Hobby authorized dealer to ensure authentic high-quality Spektrum product. Horizon Hobby, LLC disclaims all support and warranty with regards, but not limited to, compatibility and performance of counterfeit products or products claiming compatibility with DSM or Spektrum.

Age Recommendation: Not for children under 14 years. This is not a toy.

SAFETY PRECAUTIONS AND WARNINGS

- Always keep a safe distance in all directions around your model to avoid collisions or injury. This model is controlled by a radio signal subject to interference from many sources outside your control. Interference can cause momentary loss of control.
- Always operate your model in open spaces away from full-size vehicles, traffic and people.
- Always carefully follow the directions and warnings for this and any optional support equipment (chargers, rechargeable battery packs, etc.).
- Always keep all chemicals, small parts and anything electrical out of the reach of children.
- Always avoid water exposure to all equipment not specifically designed and protected for this purpose. Moisture causes damage to electronics.
- Never place any portion of the model in your mouth as it could cause serious injury or even death.
- Never operate your model with low transmitter batteries.

TABLE OF CONTENTS

Register your Losi Product Online.....	2
Components	2
Recommended Accessories	
Tools Included	
Contents	3
Water-Resistant Vehicle with Waterproof Electronics.....	3
Quick Start.....	3
Charging Warnings.....	4
Charging the Battery	4
Installing the Battery and Powering ON the Vehicle	4
Spektrum DX2E Radio System	5
Installing the Transmitter Batteries	
SRS4201 Stability Assist Receiver	6
AVC - Active Vehicle Control	
Binding and Calibrating the Receiver	
Control Test.....	6
Before Running Your Vehicle	6
Driving Precautions	6
Run Time.....	6
Tazer Mini Brushless Waterproof ESC	7
Tazer Mini Brushless Motor, 4500Kv	7
Tuning, Adjusting & Maintaining your Vehicle.....	8
Changing the Travel Adjust Settings	8
Service/Repair	8
Disabling the Stability Assist Function	8
Troubleshooting Guide	8
Limited Warranty	9
FCC Information.....	10
IC Information.....	10
Compliance Information for the European Union.....	10
Parts Listings	38
Optional Parts	39
Exploded View	40
Setup Sheet.....	44

REGISTER YOUR LOSI PRODUCT ONLINE

Register your vehicle now and be the first to find out about the latest option parts, product updates and more. Click on the Support tab at WWW.LOSI.COM and follow the product registration link to stay connected.

COMPONENTS

- 1/14-Scale Mini 8IGHT-T™ RTR vehicle
- Spektrum™ DX2E 2.4GHz DSMR™ Radio System
- SRS4201 4-Channel DSMR Receiver with Active Vehicle Control™ (AVC®) technology
- Dynamite® Tazer™ Mini Brushless Waterproof ESC
- Dynamite Fuze™ Mini Brushless Motor, 4500Kv
- Spektrum S500 Sport Servo
- Dynamite 7.2V 1200mAh Ni-MH Battery Long with EC3™ Connector
- Losi® AC Wall Charger with EC3 Connector (110V)
- 4 AA batteries (for transmitter)

RECOMMENDED ACCESSORIES

- Soft bristle brush for cleaning
- #0 or #1 Phillips screwdriver
- 2.0mm Hex L wrench
- Thread Lock

TOOLS INCLUDED

- Turnbuckle Wrench
- 4-Way Wrench
- 1.5mm Hex "L" Wrench
- Slipper Adjustment Tool

Use only Dynamite tools or other high-quality tools. Use of inexpensive tools can cause damage to the small screws and parts used on this type of model.

CONTENTS

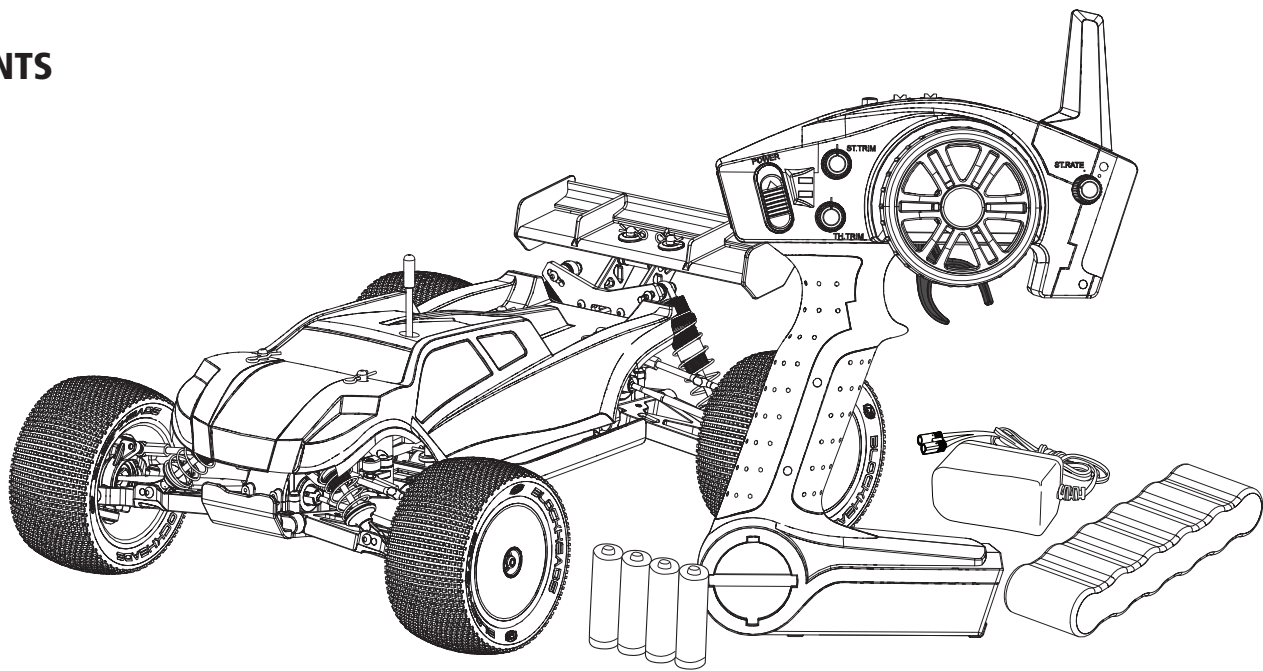

WATER-RESISTANT VEHICLE WITH WATERPROOF ELECTRONICS

Your new Horizon Hobby vehicle has been designed and built with a combination of waterproof and water-resistant components to allow you to operate the product in many “wet conditions”, including puddles, creeks, wet grass, snow and even rain.

While the entire vehicle is highly water-resistant, it is not completely waterproof and your vehicle should NOT be treated like a submarine. The various electronic components used in the vehicle, such as the Electronic Speed Control (ESC), servo(s) and receiver are waterproof, however, most of the mechanical components are water-resistant and should not be submerged.

Metal parts, including the bearings, hinge pins, screws and nuts, as well as the contacts in the electrical cables, will be susceptible to corrosion if additional maintenance is not performed after running in wet conditions. To maximize the long-term performance of your vehicle and to keep the warranty intact, the procedures described in the “Wet Conditions Maintenance” section below must be performed regularly if you choose to run in wet conditions. If you are not willing to perform the additional care and maintenance required, then you should not operate the vehicle in those conditions.

CAUTION: Failure to exercise caution while using this product and complying with the following precautions could result in product malfunction and/or void the warranty.

GENERAL PRECAUTIONS

- Read through the wet conditions maintenance procedures and make sure that you have all the tools you will need to properly maintain your vehicle.
- Not all batteries can be used in wet conditions. Consult the battery manufacturer before use. Caution should be taken when using Li-Po batteries in wet conditions.
- Most transmitters are not water-resistant. Consult your transmitter’s manual or the manufacturer before operation.
- Never operate your transmitter or vehicle where lightning may be present.
- Do not operate your vehicle where it could come in contact with salt water (ocean water or water on salt-covered roads), contaminated or polluted water. Salt water is very conductive and highly corrosive, so use caution.
- Even minimal water contact can reduce the life of your motor if it has not been certified as water-resistant or waterproof. If the motor becomes excessively wet, apply very light throttle until the water is mostly removed from the motor. Running a wet motor at high speeds may rapidly damage the motor.

QUICK START

Please read the entire manual to gain a full understanding of the Mini 8IGHT-T RTR vehicle, fine-tuning the setup and performing maintenance.

1. Read the safety precautions found in this manual.
2. Charge the battery. Refer to the included charging warnings and instructions for battery charging information.
3. Install the AA batteries in the transmitter. Only use alkaline or rechargeable batteries.
4. Install a fully charged battery in the vehicle.
5. Power ON the transmitter and then the vehicle. Always power the transmitter ON before the vehicle and power it OFF after the vehicle has been powered OFF.
6. Check the steering and throttle control directions. Verify that the servos are moving in the correct direction.
7. Drive your vehicle.
8. Perform any necessary maintenance.

- Driving in wet conditions can reduce the life of the motor. The additional resistance of operating in water causes excess strain. Alter the gear ratio by using a smaller pinion or larger spur gear. This will increase torque (and motor life) when running in mud, deeper puddles, or any wet conditions that will increase the load on the motor for an extended period of time.

WET CONDITIONS MAINTENANCE

- Drain any water that has collected in the tires by spinning them at high speed. With the body removed, place the vehicle upside down and pull full throttle for a few short bursts until the water has been removed.

CAUTION: Always keep hands, fingers, tools and any loose or hanging objects away from rotating parts when performing the above drying technique.

- Remove the battery pack(s) and dry the contacts. If you have an air compressor or a can of compressed air, blow out any water that may be inside the recessed connector housing.
- Remove the tires/wheels from the vehicle and gently rinse the mud and dirt off with a garden hose. Avoid rinsing the bearings and transmission.

NOTICE: Never use a pressure washer to clean your vehicle.

- Use an air compressor or a can of compressed air to dry the vehicle and help remove any water that may have gotten into small crevices or corners.
- Spray the bearings, drive train, fasteners and other metal parts with a water-displacing light oil. Do not spray the motor.
- Let the vehicle air dry before you store it. Water (and oil) may continue to drip for a few hours.
- Increase the frequency of disassembly, inspection and lubrication of the following:
 - Front and rear axle hub assembly bearings.
 - All transmission cases, gears and differentials.
 - Motor—clean with an aerosol motor cleaner and re-oil the bushings with lightweight motor oil.

CHARGING WARNINGS

⚠ WARNING: Failure to exercise caution while using this product and comply with the following warnings could result in product malfunction, electrical issues, excessive heat, FIRE, and ultimately injury and property damage.

- **Never leave the battery and charger unattended during use.**
- **Never charge batteries overnight.**
- Read all safety precautions and literature prior to use of this product.
- Never allow children under 14 years of age to charge battery packs.
- Never attempt to charge dead or damaged batteries.
- Never charge a battery if the cable has been pinched or shorted.
- Never allow batteries or charger to come into contact with moisture at any time.
- Never charge batteries in extremely hot or cold places (recommended between 50–80°F (10–26°C)) or place in direct sunlight.

- Always use only Ni-MH rechargeable batteries. This charger cannot charge batteries such as "heavy duty", "alkaline", "mercury" or "lithium" battery.
- Always connect to the charger correctly.
- Always disconnect the battery and charger after charging and let them cool between charges.
- Always inspect the battery before charging.
- Always terminate all processes and contact Horizon Hobby if the product malfunctions.
- Always make sure you know the specifications of the battery to be charged or discharged to ensure it meets the requirements of this charger.
- Always constantly monitor the temperature of the battery pack while charging.
- Always end the charging process if the charger or battery becomes hot to the touch or starts to change form during the charge process.
- Always charge in a well ventilated area.

CHARGING THE BATTERY

Charge only batteries that are cool to the touch and are not damaged. Inspect the battery to make sure it is not damaged e.g., swollen, bent, broken or punctured.

1. Connect the charger to an AC power source, noting proper polarity.
2. Connect the battery connector to the charger connector.
3. Let the battery charge for 3 hours.
4. Disconnect the battery from the charger.
5. Disconnect the charger from the AC power source.

⚠ CAUTION: If at any time during the charging process the battery becomes hot to the touch, disconnect the battery immediately and discontinue the charging process.

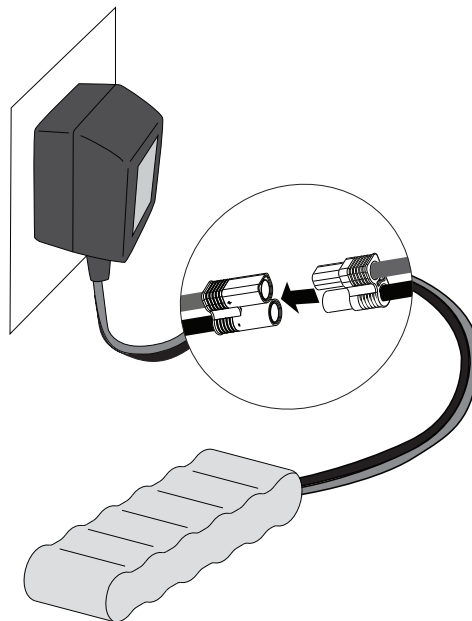

INSTALLING THE BATTERY AND POWERING ON THE VEHICLE

1. Remove the body clips and remove the body.
2. Remove the body clips from the battery strap posts and remove the battery strap.
3. Install the fully charged battery in vehicle.
4. Ensure the ESC is powered off.
5. Connect the battery to the ESC.
6. Reinstall the battery strap and body clips.
7. Center the ST TRIM and TH TRIM on the transmitter. Power on the transmitter.
8. Power on the ESC. The vehicle and receiver **MUST** remain motionless for at least 2 seconds.
9. Reinstall the body and body clips on the vehicle.

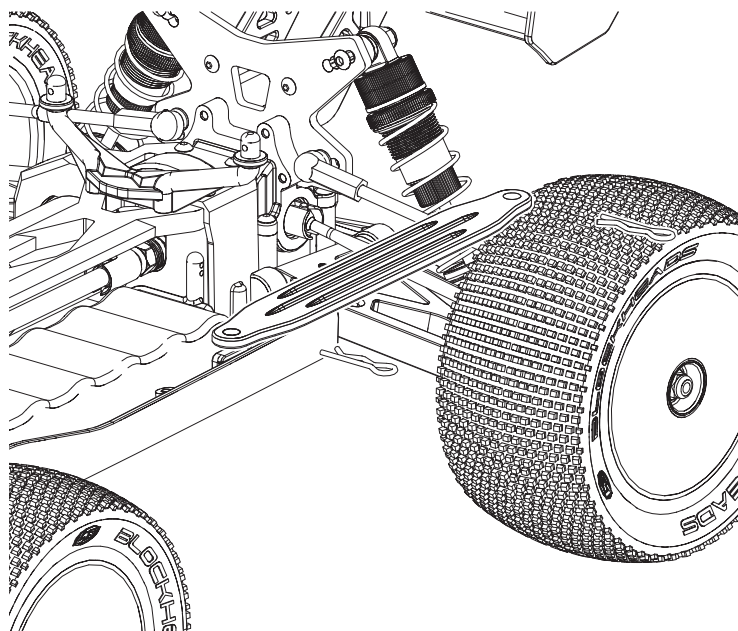
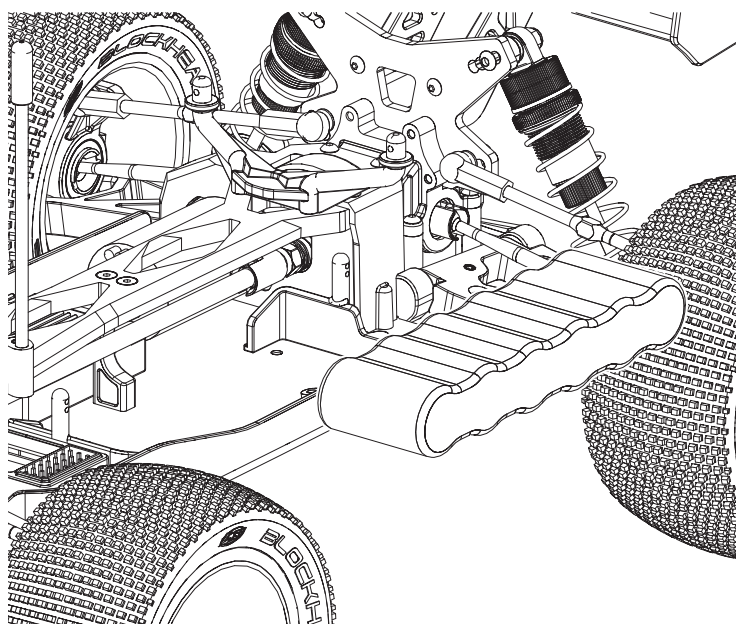

SPEKTRUM DX2E RADIO SYSTEM

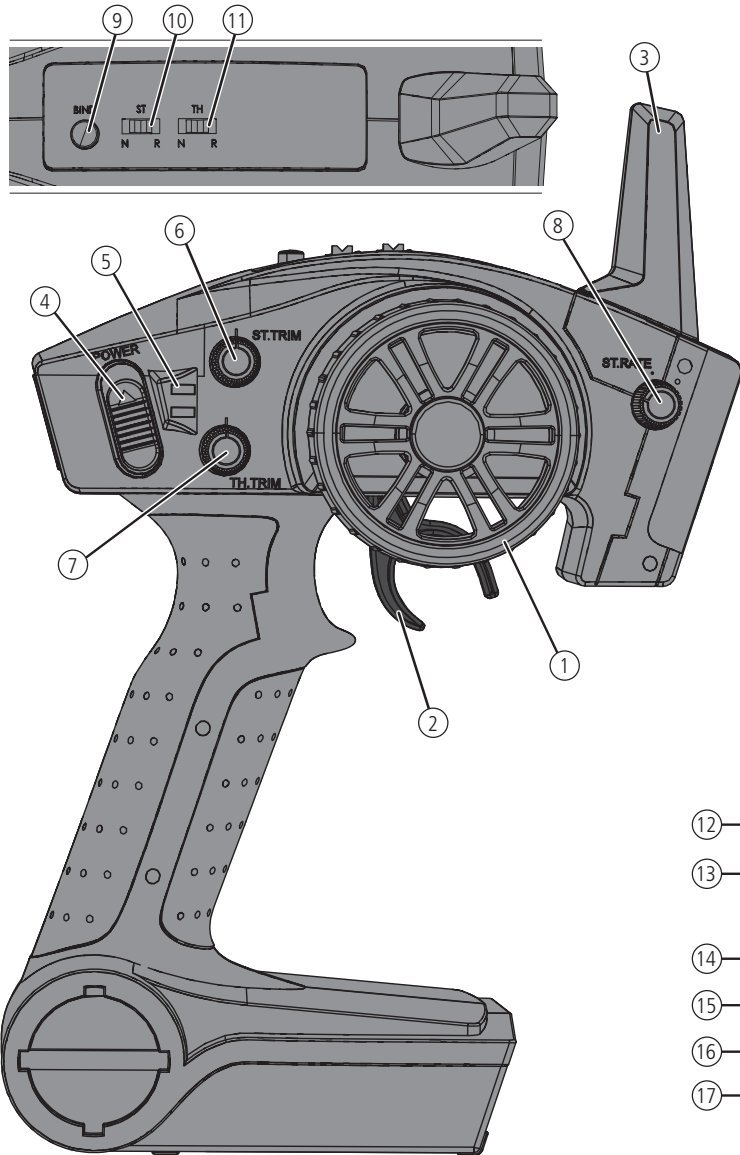

1. **Steering Wheel** Controls direction (left/right) of the model
2. **Throttle Trigger** Controls speed and direction (forward/brake/reverse) of the model
3. **Antenna** Transmits the signal to the model
4. **ON/OFF Switch** Turns the power ON/OFF for the transmitter
5. **Indicator Lights**
 - Solid green light—indicates adequate battery power
 - Flashing green light—indicates the battery voltage is critically low. Replace batteries
6. **ST Trim** Adjusts the total steering travel
7. **TH Trim** Adjusts the total throttle travel
8. **ST Rate** Adjusts the sensitivity of AVC
9. **BIND Button** Puts the transmitter into Bind Mode
10. **ST. REV** Reverses the function of the steering when the wheel is turned left or right
11. **TH. REV** Reverses the function of the speed control when pulled back or pushed forward

SRS4201 AVC TECHNOLOGY RECEIVER

12. BIND
13. DISABLE
14. AUX 2
15. AUX 1
16. THR
17. STR

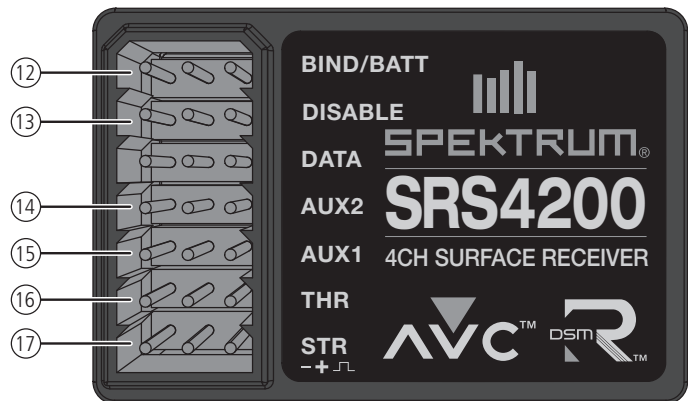

INSTALLING THE TRANSMITTER BATTERIES

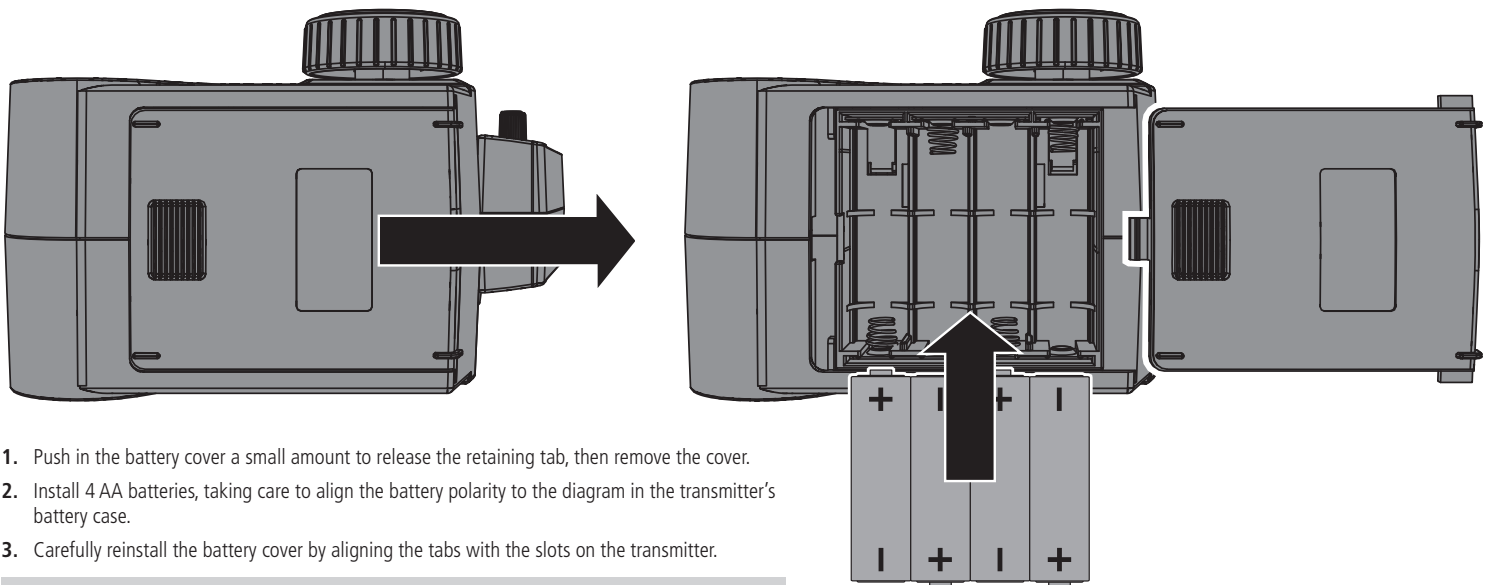

1. Push in the battery cover a small amount to release the retaining tab, then remove the cover.
2. Install 4 AA batteries, taking care to align the battery polarity to the diagram in the transmitter's battery case.
3. Carefully reinstall the battery cover by aligning the tabs with the slots on the transmitter.

CAUTION: Do not remove the transmitter batteries while the model is powered on or while operating, as a loss of model control, damage or injury can result.

For more information on the transmitter, go to www.horizonhobby.com and click on the support tab for the Spektrum DX2E to download the instruction manual.

SRS4201 STABILITY ASSIST RECEIVER

AVC – ACTIVE VEHICLE CONTROL

The Spektrum SRS4201 receiver features Active Vehicle Control™ (AVC®) technology that responds similar to traction control in full-scale vehicles. In addition to traction control, AVC technology also increases steering stability during high-speed driving or while driving over rough terrain. As you increase the AVC sensitivity, the system increases steering stability and traction control, similar to reducing the amount of steering rate in a computer transmitter. Reducing the sensitivity value increases the amount of steering control from the transmitter. The SRS4201 receiver also enables you to quickly turn AVC on or off if you participate in organized racing.

IMPORTANT: You must use digital servos with the SRS4201 receiver. Using analog servos will reduce the performance of the system and may cause analog servos to overheat.

AVC SENSITIVITY

The ST RATE dial adjusts the sensitivity, or stability, value in the receiver. If you increase the sensitivity, the AVC system becomes more sensitive to the vehicle drifting left or right. You would use maximum sensitivity during high-speed driving or drag racing, when you want the vehicle to stay in a straight line. As the sensitivity value increases, the amount of steering travel decreases.

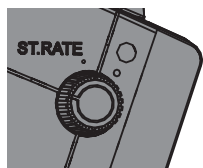

Turn the ST RATE knob counter-clockwise to reduce the sensitivity.

Turn the ST RATE knob clockwise to increase the sensitivity.

IMPORTANT: The ST RATE knob will only adjust the sensitivity when the transmitter is bound to a DSMR™ receiver. When the transmitter is bound to a DSM®, DSM2® or DSM Marine receiver, the ST RATE knob controls the steering dual rate.

BINDING AND CALIBRATING THE RECEIVER

Your Spektrum DX2E comes prebound to the vehicle; however, if you need to rebind or calibrate the receiver, follow the instructions below.

1. Insert the Bind Plug in the BIND port on the receiver.
2. Connect a fully charged battery pack to the ESC.
3. Power on the ESC. The orange LED flashes, indicating the receiver is in bind mode.
4. Center the ST TRIM and TH TRIM dials on the transmitter.
5. Press and hold the BIND button while powering on the transmitter.
6. Release the BIND button when the orange LED slowly flashes. The transmitter and receiver are linked when the orange LED is solid.
7. Pull the transmitter trigger to Full Throttle.
8. Push the transmitter trigger to Full Brake, then return the trigger to center.
9. Turn the transmitter steering wheel to Full Right.
10. Turn the transmitter steering wheel to Full Left, then return the steering wheel to center. The orange LED flashes once.
11. Remove the Bind Plug, then power off the receiver to save the settings.
12. Power off the transmitter.

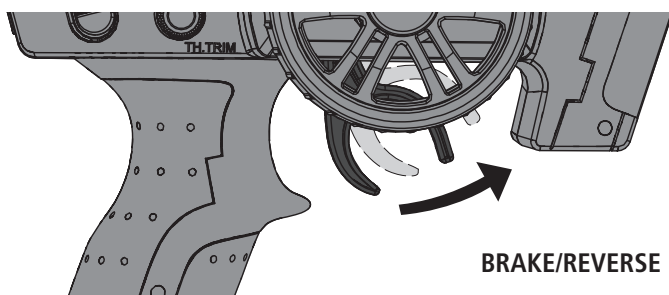
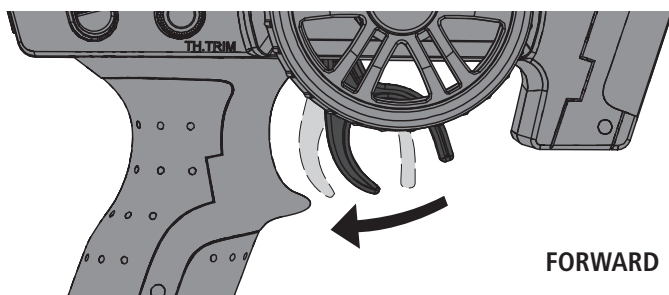

CONTROL TEST

Perform a control test with the vehicle wheels off the ground. If the wheels rotate after the vehicle is powered ON, adjust the TH Trim knob until they stop. To make the wheels move forward, pull the trigger. To reverse them, wait for the wheels to stop, then push the trigger. When moving forward, the wheels should maintain a straight line without any steering wheel input. If not, adjust the ST Trim knob, so the wheels maintain a straight line without having to turn the steering wheel.

BEFORE RUNNING YOUR VEHICLE

1. Break in the differentials. While holding the chassis with only the left side tires firmly on the ground, give the car about 1/8 throttle for 30 seconds. The right side tires should spin freely during this time. Repeat this with only the right side tires firmly on the ground, allowing the left side tires to spin freely. Repeat this 2–3 times.
2. Check for free suspension movement. All suspension arms and steering components should move freely. Any binds will cause the car to handle poorly.
3. Charge the battery.
4. Check the calibration of the ESC. If recalibration is required, refer to the Tazer Mini Brushless ESC section.
5. Adjust the transmitter settings to your desired configuration.

DRIVING PRECAUTIONS

- Maintain sight of the vehicle at all times.
- Inspect the vehicle for loose wheel hardware.
- Inspect the steering assembly for any loose hardware. Driving the vehicle off-road can cause fasteners to loosen over time.
- Do not drive the vehicle in tall grass. Doing so can damage the vehicle or electronics.
- Stop driving the vehicle when you notice a lack of power. Driving the vehicle when the battery is discharged can cause the receiver to power off. You may lose control of the vehicle.
- Do not apply the throttle in forward or reverse if the vehicle is stuck. Applying throttle in this instance can damage the motor or ESC.
- After driving the vehicle, allow the electronics to cool to ambient temperature before using the next battery pack.

RUN TIME

The largest factor in run time is the capacity of the battery pack. A larger mAh rating increases the amount of run time experienced.

The condition of a battery pack is also an important factor in both run time and speed. The battery connectors may become hot during driving. Batteries will lose performance and capacity over time.

Driving the vehicle from a stop to full speed repeatedly will damage the batteries and electronics over time. Sudden acceleration will also lead to shorter run times.

TO IMPROVE RUN TIMES

- Keep your vehicle clean and well maintained.
- Allow more airflow to the ESC and motor.
- Change the gearing to a lower ratio. A lower ratio lowers the operating temperature of the electronics. Use a smaller pinion gear or larger spur gear to lower the gear ratio.
- Use a battery pack with a higher mAh rating.

TAZER MINI BRUSHLESS WATERPROOF ESC (DYN51425)

ESC PROGRAMMING PROCEDURE

1. Power ON the transmitter and set the transmitter's throttle endpoint travel to maximum and the throttle trim to the center position.
2. Leave the throttle trigger at center, then power ON the ESC.
3. Press and hold the Battery Chemistry Button on the power switch for 3 seconds. The LED flashes the current battery chemistry (red = Ni-MH, green = Li-Po).
4. Continue holding the Battery Chemistry Button for another 6 seconds. The ESC changes battery chemistry and the LED flashes the new battery chemistry.
5. Power OFF the ESC. The ESC saves the setting until it is changed.

TRANSMITTER/ESC ENDPOINT CALIBRATION

- a. Power OFF the ESC.
- b. Ensure your transmitter is powered ON, the throttle is not reversed, the throttle trim is neutral and the throttle travel range is at 100%. Disable any special functions such as ABS, etc.
- c. Press the SET button while powering on the ESC. Release the button as soon as the red LED starts to flash.
- d. Calibrate the throttle points by pressing the SET button once after each step.
 - Neutral point (1 flash) - leave the throttle at rest, untouched
 - Full throttle (2 flashes) - push the throttle fully forward
 - Full brakes/reverse (3 flashes) - push the throttle fully forward
- e. The ESC will beep 3 times to indicate programming is complete.

FUZE MINI BRUSHLESS MOTOR, 4500KV

PINION	SPUR	BATTERY	GEARING	COMMENTS
14T	62T	Ni-MH	OK	This is the stock gearing. If you use a 2S-3S Li-Po, you will need to gear down, or you will overheat the motor.
12T (LOS1862)	62T	2S Li-Po	OK	This gearing is optimal for a 2S Li-Po.
10T (LOS1861)	62T	3S Li-Po	OK	This gearing is optimal for a 3S Li-Po.

CHANGING THE PINION/GEAR RATIO

Your vehicle comes with the 14T pinion gear installed for the included 6C Ni-MH battery. If you want to use a 2S-3S Li-Po battery, refer to the Gearing Chart for the proper gearing.

1. Remove the 6 screws securing the gear cover and remove the gear cover.
2. Loosen the motor screws and slide the motor back.
3. Loosen the setscrew and remove the installed pinion gear.
4. Place the new pinion on the end of the motor shaft so the setscrew is located over the flat on the shaft.
5. Position it so the teeth line up with the spur gear and secure by tightening the setscrew.
6. Tighten the motor screws and reinstall the gear cover.

SETTING THE GEAR MESH

The gear mesh has already been set at the factory. Setting it is only necessary when changing motors or gears. Proper gear mesh (how gear teeth meet) is important to the performance of the vehicle. When the gear mesh is too loose, the spur gear could be damaged by the pinion gear of the motor. If the mesh is too tight, speed could be limited and the motor and ESC will overheat.

1. Remove the 6 screws securing the gear cover and remove the gear cover.
2. Loosen the motor screws and slide the motor back.
3. Put a small piece of paper between the pinion and spur gears.
4. Push the gears together while tightening the motor screws.
5. Remove the paper. Check the mesh at 3-5 different locations around the spur gear for a small amount of movement.
6. Reinstall the gear cover.

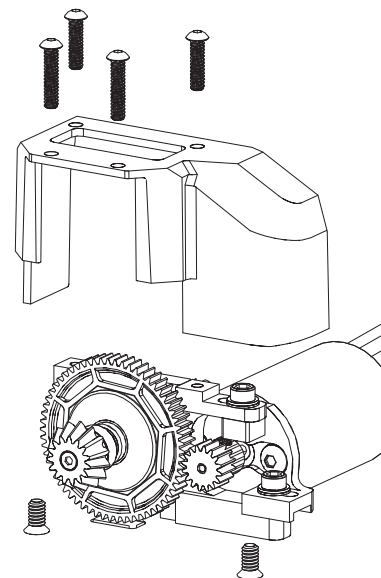

TUNING, ADJUSTING & MAINTAINING YOUR VEHICLE

- Examine your vehicle on a regular basis.
- Use a brush to remove dirt and dust.
- Look for damage to the suspension arms and other molded parts.
- Re-glue the tires to the wheels, if necessary.
- Use suitable tools to tighten fasteners.
- Make sure the camber and steering linkages are not bent. Replace any bent linkages.
- Adjust the Toe and Camber settings, if necessary.
- Remove the shocks and inspect them for damage. Rebuild the shocks if oil is leaking.
- Inspect electronics and batteries for exposed wires. Repair exposed wires with shrink-wrap or replace the wire.
- Make sure the ESC and receiver are secure on the chassis. Replace the double-sided tape, if necessary.
- Power on the transmitter. If the green LED is dim or off, replace the AA batteries in your transmitter.
- Check the spur gear for wear.

CHANGING THE TRAVEL ADJUST SETTINGS

1. Hold the trigger in the full brake position and steering wheel in the full right position while powering on the transmitter. The LED flashes rapidly, indicating the programming mode is active.
2. **Throttle End Point:** Continue holding full throttle. Turn the TH TRIM knob to adjust the full throttle end point.
3. **Brake End Point:** Hold the trigger in the full brake position. Turn the TH TRIM knob to adjust the full brake end point. Return the trigger to the center position.
4. **Left Steering End Point:** Hold the steering wheel in the full left position. Turn the ST TRIM knob to adjust the left end point.
5. **Right Steering End Point:** Hold the steering wheel in the full right position. Turn the ST TRIM knob to adjust the right end point. Return the steering wheel to the center position.
6. Power off the transmitter to save the travel adjust settings.

The minimum travel is 75%, and the maximum travel is 150%.

IMPORTANT: If the travel is changed on the DX2E, you must rebind and calibrate the SRS4201.

SERVICE/REPAIR

RADIO/SPEED CONTROL & MOTOR

If any problems other than those covered in the troubleshooting section arise, please call the appropriate electronics service department. They will be able to give the problem additional specific attention and provide instructions for the solution.

MAINTENANCE

If any questions other than those covered in the troubleshooting or maintenance sections arise, please call the appropriate Horizon product support department.

CLEANING

Performance can be hindered if dirt gets in any of the moving suspension parts. Use compressed air, a soft paintbrush, or a toothbrush to remove dust or dirt. Avoid using solvents or chemicals as they can actually wash dirt into the bearings or moving parts, as well as cause damage to the electronics.

DISABLING THE STABILITY ASSIST FUNCTION

If you participate in organized racing, you may be required to turn Stability Assist off. To turn Stability Assist off:

1. Insert a Bind Plug in the BIND port on the receiver.
2. Insert a second Bind Plug in the DISABLE port on the receiver.
3. Connect a fully charged battery pack to the ESC.
4. Power on the ESC. The orange LED flashes, indicating the receiver is in bind mode.
5. Center the ST TRIM and TH TRIM dials on the transmitter.
6. Press and hold the BIND button while powering on the transmitter.
7. Release the BIND button when the orange LED slowly flashes. The transmitter and receiver are linked when the orange LED is solid.
8. Pull the transmitter trigger to Full Throttle.
9. Push the transmitter trigger to Full Brake, then return the trigger to center.
10. Turn the transmitter steering wheel to Full Right.
11. Turn the transmitter steering wheel to Full Left, then return the steering wheel to center. The orange LED flashes once.
12. Remove the Bind Plugs, then power off the receiver to save the settings.
13. Power off the transmitter.

IMPORTANT: You must calibrate the receiver each time it is placed in bind mode.

To activate AVC, see the steps in "Calibrating the Receiver".

TROUBLESHOOTING GUIDE

PROBLEM	POSSIBLE CAUSE	SOLUTION
Vehicle does not operate	Battery not charged or plugged in	Charge battery/plug in
	ESC switch not "On"	Turn on ESC switch
	Transmitter not "On" or low battery	Turn on/replace batteries
Motor runs but rear wheels do not rotate	Pinion not meshing with spur gear	Adjust pinion/spur mesh
	Pinion spinning on motor shaft	Tighten pinion gear setscrew on motor shaft flat spot
	Transmission gears stripped	Replace transmission gears
	Drive pin broken	Check and replace drive pin
Steering does not work	Servo plug not in receiver properly	Make sure the steering servo plug is connected to the receiver steering channel, noting proper polarity
	Servo gears or motor damaged	Replace or repair servo
Will not turn one direction	Servo gears damaged	Replace or repair servo
Motor does not run	Motor wire solder joint is damaged	Resolder the motor wire with the proper equipment
	Motor wire broken	Repair or replace as needed
	ESC damaged	Contact Horizon Hobby Product Support
ESC gets hot	Motor over-geared	Use smaller pinion or larger spur gear
	Driveline bound up	Check wheels and transmission for binding
Poor run time and/or sluggish acceleration	Battery pack not fully charged	Recharge battery
	Charger not allowing full charge	Try another charger
	Driveline bound up	Check wheels, transmission for binding
Poor range and/or glitching	Transmitter batteries low	Check and replace
	Vehicle battery low	Recharge battery
	Loose plugs or wires	Check all wire connections and plugs

PROBLEM	POSSIBLE CAUSE	SOLUTION
The front wheels oscillate	The steering gain is set too high	Turn down the steering gain
The front wheels turn the wrong way when the car slides/rotates	The steering channel was reversed after calibration	Rebind and calibrate
The throttle does not reduce when the car slides/rotates	The steering channel was reversed after calibration	Rebind and calibrate

LIMITED WARRANTY

What this Warranty Covers

Horizon Hobby, LLC ("Horizon") warrants to the original purchaser that the product purchased (the "Product") will be free from defects in materials and workmanship at the date of purchase.

What is Not Covered

This warranty is not transferable and does not cover (i) cosmetic damage, (ii) damage due to acts of God, accident, misuse, abuse, negligence, commercial use, or due to improper use, installation, operation or maintenance, (iii) modification of or to any part of the Product, (iv) attempted service by anyone other than a Horizon Hobby authorized service center, (v) Product not purchased from an authorized Horizon dealer, or (vi) Product not compliant with applicable technical regulations.

OTHER THAN THE EXPRESS WARRANTY ABOVE, HORIZON MAKES NO OTHER WARRANTY OR REPRESENTATION, AND HEREBY DISCLAIMS ANY AND ALL IMPLIED WARRANTIES, INCLUDING, WITHOUT LIMITATION, THE IMPLIED WARRANTIES OF NON-INFRINGEMENT, MERCHANTABILITY AND FITNESS FOR A PARTICULAR PURPOSE. THE PURCHASER ACKNOWLEDGES THAT THEY ALONE HAVE DETERMINED THAT THE PRODUCT WILL SUITABLY MEET THE REQUIREMENTS OF THE PURCHASER'S INTENDED USE.

Purchaser's Remedy

Horizon's sole obligation and purchaser's sole and exclusive remedy shall be that Horizon will, at its option, either (i) service, or (ii) replace, any Product determined by Horizon to be defective. Horizon reserves the right to inspect any and all Product(s) involved in a warranty claim. Service or replacement decisions are at the sole discretion of Horizon. Proof of purchase is required for all warranty claims. SERVICE OR REPLACEMENT AS PROVIDED UNDER THIS WARRANTY IS THE PURCHASER'S SOLE AND EXCLUSIVE REMEDY.

Limitation of Liability

HORIZON SHALL NOT BE LIABLE FOR SPECIAL, INDIRECT, INCIDENTAL OR CONSEQUENTIAL DAMAGES, LOSS OF PROFITS OR PRODUCTION OR COMMERCIAL LOSS IN ANY WAY, REGARDLESS OF WHETHER SUCH CLAIM IS BASED IN CONTRACT, WARRANTY, TORT, NEGLIGENCE, STRICT LIABILITY OR ANY OTHER THEORY OF LIABILITY, EVEN IF HORIZON HAS BEEN ADVISED OF THE POSSIBILITY OF SUCH DAMAGES. Further, in no event shall the liability of Horizon exceed the individual price of the Product on which liability is asserted. As Horizon has no control over use, setup, final assembly, modification or misuse, no liability shall be assumed nor accepted for any resulting damage or injury. By the act of use, setup or assembly, the user accepts all resulting liability. If you as the purchaser or user are not prepared to accept the liability associated with the use of the Product, purchaser is advised to return the Product immediately in new and unused condition to the place of purchase.

Law

These terms are governed by Illinois law (without regard to conflict of law principals). This warranty gives you specific legal rights, and you may also have other rights which vary from state to state. Horizon reserves the right to change or modify this warranty at any time without notice.

WARRANTY SERVICES

Questions, Assistance, and Services

Your local hobby store and/or place of purchase cannot provide warranty support or service. Once assembly, setup or use of the Product has been started, you must contact your local distributor or Horizon directly. This will enable Horizon to better answer your questions and service you in the event that you may need any assistance. For questions or assistance, please visit our website at www.horizonhobby.com, submit a Product Support Inquiry, or call the toll free telephone number referenced in the Warranty and Service Contact Information section to speak with a Product Support representative.

Inspection or Services

If this Product needs to be inspected or serviced and is compliant in the country you live and use the Product in, please use the Horizon Online Service Request submission process found on our website or call Horizon to obtain a Return Merchandise Authorization (RMA) number. Pack the Product securely using a shipping carton. Please note that original boxes may be included, but are not designed to withstand the rigors of shipping without additional protection. Ship via a carrier that provides tracking and insurance for lost or damaged parcels, as Horizon is not responsible for merchandise until it arrives and is accepted at our facility. An Online Service Request is available at http://www.horizonhobby.com/content/_service-center_render-service-center. If you do not have internet access, please contact Horizon Product Support to obtain a RMA number along with instructions for submitting your product for service. When calling Horizon, you will be asked to provide your complete name, street address, email address and phone number where you can be reached during business hours. When sending product into Horizon, please include your RMA number, a list of the included items, and a brief summary of the problem. A copy of your original sales receipt must be included for warranty consideration. Be sure your name, address, and RMA number are clearly written on the outside of the shipping carton.

NOTICE: Do not ship Li-Po batteries to Horizon. If you have any issue with a Li-Po battery, please contact the appropriate Horizon Product Support office.

Warranty Requirements

For Warranty consideration, you must include your original sales receipt verifying the proof-of-purchase date. Provided warranty conditions have been met, your Product will be serviced or replaced free of charge. Service or replacement decisions are at the sole discretion of Horizon.

Non-Warranty Service

Should your service not be covered by warranty, service will be completed and payment will be required without notification or estimate of the expense unless the expense exceeds 50% of the retail purchase cost.

By submitting the item for service you are agreeing to payment of the service without notification. Service estimates are available upon request. You must include this request with your item submitted for service. Non-warranty service estimates will be billed a minimum of ½ hour of labor. In addition you will be billed for return freight. Horizon accepts money orders and cashier's checks, as well as Visa, MasterCard, American Express, and Discover cards. By submitting any item to Horizon for service, you are agreeing to Horizon's Terms and Conditions found on our website http://www.horizonhobby.com/content/_service-center_render-service-center.

ATTENTION: Horizon service is limited to Product compliant in the country of use and ownership. If received, a non-compliant Product will not be serviced. Further, the sender will be responsible for arranging return shipment of the un-serviced Product, through a carrier of the sender's choice and at the sender's expense. Horizon will hold non-compliant Product for a period of 60 days from notification, after which it will be discarded.

WARRANTY AND SERVICE CONTACT INFORMATION

COUNTRY OF PURCHASE	HORIZON HOBBY	CONTACT INFORMATION	ADDRESS
United States of America	Horizon Service Center (Repairs and Repair Requests)	servicecenter.horizonhobby.com/RequestForm/	4105 Fieldstone Rd Champaign, Illinois, 61822 USA
	Horizon Product Support (Product Technical Assistance)	www.quickbase.com/db/bghj7ey8c?a=GenNewRecord 888-959-2305	
	Sales	sales@horizonhobby.com 888-959-2305	
United Kingdom	Service/Parts/Sales: Horizon Hobby Limited	sales@horizonhobby.co.uk +44 (0) 1279 641 097	Units 1–4 Ployters Rd Staple Tye Harlow, Essex CM18 7NS, United Kingdom
Germany	Horizon Technischer Service Sales: Horizon Hobby GmbH	service@horizonhobby.de +49 (0) 4121 2655 100	Christian-Junge-Straße 1 25337 Elmshorn, Germany
France	Service/Parts/Sales: Horizon Hobby SAS	infofrance@horizonhobby.com +33 (0) 1 60 18 34 90	11 Rue Georges Charpak 77127 Lieusaint, France
China	Service/Parts/Sales: Horizon Hobby - China	info@horizonhobby.com.cn +86 (021) 5180 9868	Room 506, No. 97 Changshou Rd. Shanghai, China 200060

FCC INFORMATION

This device complies with part 15 of the FCC rules. Operation is subject to the following two conditions: (1) This device may not cause harmful interference, and (2) this device must accept any interference received, including interference that may cause undesired operation.



CAUTION: Changes or modifications not expressly approved by the party responsible for compliance could void the user's authority to operate the equipment.

This product contains a radio transmitter with wireless technology which has been tested and found to be compliant with the applicable regulations governing a radio transmitter in the 2.400 GHz to 2.4835 GHz frequency range.

ANTENNA SEPARATION DISTANCE

When operating your Spektrum transmitter, please be sure to maintain a separation distance of at least 5 cm between your body (excluding fingers, hands, wrists, ankles and feet) and the antenna to meet RF exposure safety requirements as determined by FCC regulations.

The following illustrations show the approximate 5 cm RF exposure area and typical hand placement when operating your Spektrum transmitter.

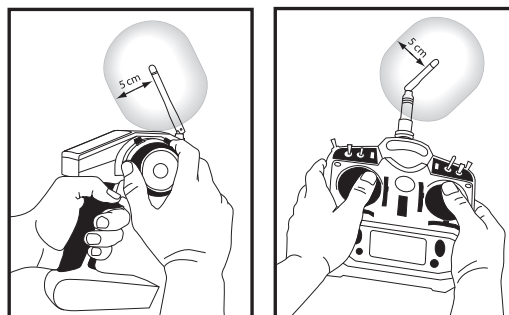

IC INFORMATION

This device complies with Industry Canada licence-exempt RSS standard(s). Operation is subject to the following two conditions: (1) this device may not cause interference, and (2) this device must accept any interference, including interference that may cause undesired operation of the device.

COMPLIANCE INFORMATION FOR THE EUROPEAN UNION

CE DECLARATION OF CONFORMITY (in accordance with ISO/IEC 17050-1)

No. HH2014022804U1

Product(s): Mini 8IGHT-T RTR, AVC: 1/14 4WD Truggy (includes Spektrum DX2E Transmitter with Spektrum SRS4201 Receiver)

Item Number(s): LOS01000I

Equipment class: 1

The object of declaration described above is in conformity with the requirements of the specifications listed below, following the provisions of the European R&TTE Directive 1999/5/EC, EMC Directive 2004/108/EC and LVD Directive 2006/95/EC:

EN 300-328 V1.8.1

EN 301 489-1 V1.9.2: 2012

EN 301 489-17 V2.1.1: 2009

EN 60950-1:2006+A11:2009+A1:2010+A12: 2011

EN 62311:2008

EN 55022:2010 + AC:2011

EN 55024:2010

EN 61000-3-2:2006+A1:2009+A2:2009

EN 61000-3-3:2008

Signed for and on behalf of:

Horizon Hobby, LLC
Champaign, IL USA
December 19, 2014

Mike Dunne
Executive Vice President
Product Divisions
Horizon Hobby, LLC



INSTRUCTIONS FOR DISPOSAL OF WEEE BY USERS IN THE EUROPEAN UNION

This product must not be disposed of with other waste. Instead, it is the user's responsibility to dispose of their waste equipment by handing it over to a designated collection point for the recycling of waste electrical and electronic equipment. The separate collection and recycling of your waste equipment at the time of disposal will help to conserve natural resources and ensure that it is recycled in a manner that protects human health and the environment. For more information about where you can drop off your waste equipment for recycling, please contact your local city office, your household waste disposal service or where you purchased the product.

PARTS LISTINGS/TEILELISTE/LISTE DES PIÈCES/ELENCO COMPONENTI

PART #	ENGLISH	DEUTSCH	FRANÇAIS	ITALIANO
DYNS1425	Tazer Mini Brushless Waterproof ESC	Tazer Mini Brushless wasserdichter Regler	Mini contrôleur brushless Tazer étanche	ESC brushless impermeabile Tazer Mini
DYN1473	7.2V 1200mAh Ni-MH Battery Long with EC3™ Connector	Dynamite 7.2V 1200mAh NiMH Battery, Lang m/EC3: Minis	Batterie 7.2V 1200mA Ni-MH avec prise EC3	Batteria lunga 7.2V 1200mAh Ni-MH con connettore EC3
DYN4830	Fuze Mini Brushless Motor, 4500Kv	Fuze Mini Brushless Motor, 4500Kv	Mini moteur brushless Fuze 4500Kv	Motore brushless Fuze Mini, 4500Kv
LOS41003	Front/Rear Wheel Set White (4): Mini 8T	Losi Mini 8T: Räder v/h weiß (4)	Set de jantes av/arr blanches (4) : Mini 8T	Set ruote bianche anter/poster (4): Mini 8T
LOS41004	Blockhead Tires Premounted (2): Mini 8T	Losi Mini 8T: Blockhead Reifen	Pneus Blockheads prémontés (2) : Mini 8T	Gomme Blockhead premontate (2): Mini 8T
LOS210000	Body Painted: Mini 8T	Losi Mini 8T: Karosserie lackiert	Carrosserie peinte : Mini 8T	Carrozzeria verniciata: Mini 8T
LOS211000	Front/Rear Shock Tower Set: Mini 8T	Losi Mini 8T: Dämpferbrücke	Support d'amortisseur av/arr : Mini 8Tc	Set torre ammort. anter/poster: Mini 8T
LOS211001	Main Chassis: Mini 8T	Chassis: Mini 8T	Châssis principal: Mini 8T	Telaio principale: Mini 8T
LOS211002	Chassis Guard Set: Mini 8T	Chassis Schützer Set: Mini 8T	Jeu de protège-châssis: Mini 8T	Set protezione telaio: Mini 8T
LOS211003	Upper Deck Support, Body Mounts: Mini 8T	Losi Mini 8T: Chassistr. u. Karosseriehalter	Renfort supérieur avec support de carrosserie : Mini 8T	Piattaforma superiore, supporto carrozzeria: Mini 8T
LOS211004	Steering Hardware Set: Mini 8T	Lenkung Hardware Set: Mini 8T	Visserie pour direction: Mini 8T	Set bulloni sterzo: Mini 8T
LOS212000	Drive Shaft Set: Mini 8T	Antriebsachse Set: Mini 8T	Jeu d'arbres d'entraînement: Mini 8T	Set albero di trasmissione: Mini 8T
LOS212001	Dogbone Set (4): Mini 8T	Rally Antriebsknochen Set: Mini 8T	Rally Ensemble de système d'entraînement (Dogbone): Mini 8T	Rally Set semiassi: Mini 8T
LOS212002	Axle Set (2): Mini 8T	Achsen Set: Mini 8T	Jeu de fusées: Mini 8T	Asse Set: Mini 8T
LOS212003	Wheel Hex Set : Mini 8T	Losi Mini 8T: Radmutterset	Set d'hexagones de roues : Mini 8T	Set ruote esagonali: Mini 8T
LOS214000	Front/Rear Suspension Arm Set: Mini 8T	Querlenker set vorne / hinten Front: Mini 8T	Bras de suspension avant/arrière: Mini 8T	Set braccio sospensione anteriore, posteriore: Mini 8T
LOS214001	Turnbuckle Set (6): Mini 8T	Gewindestangen Set: Mini 8T	Jeu de tendeurs: Mini 8T	Set tenditore: Mini 8T
LOS214002	Hinge Pin Set (4): Mini 8T	Losi Mini 8T: Hinge Pin Set (4)	Axes de suspension (4) : Mini 8T	Set perni cerniere (4): Mini 8T
LOS216000	Hardware Set: Mini 8T	Hardware Set: Mini 8T	Visserie: Mini 8T	Set bulloni: Mini 8T
LOS217000	Bearing Set: Mini 8T	Losi Mini 8T: Lager set	Set de roulements : Mini 8T	Set cuscinetto: Mini 8T
LOSA4002	Antenna Kit	Antenne	Accessoires d'antenne	Kit antenna
LOSB1335	Wing Set: Mini 8IGHT	Spoiler Set: Mini 8IGHT	Aileron: Mini 8IGHT	Set alettoni: Mini 8IGHT
LOSB1863	Pinion Gear 14T: Mini 8IGHT	Ritzel, 14Z: Mini 8IGHT	Pignon, 14 dents: Mini 8IGHT	Ruota conica, 14T: Mini 8IGHT
LOSB1887	Spindle, Hub Carrier Set: Mini 8IGHT	Achsschenkel, Radträger set: Mini 8IGHT	Ensemble fusée/moyeu/porte-fusée: Mini 8IGHT	Albero, mozzo, porta-piastre: Mini 8IGHT
LOSB1888	Suspension Mount Set: Mini 8IGHT	Querlenkerhalter set: Mini 8IGHT	Ensemble support de suspensions: Mini 8IGHT	Set montaggio sospensione: Mini 8IGHT
LOSB1891	Ball Stud Set: Mini 8IGHT	Kugelkopf set: Mini 8IGHT	Jeu de rotules: Mini 8IGHT	Set perni sferici: Mini 8IGHT
LOSB1896	Ball Cup (12): Mini 8IGHT	Kugelpfanne: Mini 8IGHT	Coupelle de rotule: Mini 8IGHT	Coppella della sfera: Mini 8IGHT
LOSB1898	Suspension Bushing Set: Mini 8IGHT	Buchse für Querlenker: Mini 8IGHT	Jeu de bagues pour suspension: Mini 8IGHT	Set boccole sospensione: Mini 8IGHT
LOSB1902	Battery Hold Down Set: Mini 8IGHT	Akkuhalter Set: Mini 8IGHT	Ensemble de fixation des accus: Mini 8IGHT	Set per tenere la batteria: Mini 8IGHT
LOSB1905	Motor Mount & Adaptor Set: Mini 8IGHT	Motorhalter und Adapter Set: Mini 8IGHT	Support moteur et ensemble adaptateur: Mini 8IGHT	Set montante e adattatore del motore: Mini 8IGHT
LOSB1908	Wing Mount & Brace Set: Mini 8IGHT	Spoilerhalter hinten: Mini 8IGHT	Ensemble support et entretoise d'aileron: Mini 8IGHT	Set montante e staffa alettone: Mini 8IGHT
LOSB1911	Front Shock Body Set: Mini 8IGHT	Stoßdämpfergehäuse vorne: Mini 8IGHT	Jeu de corps d'amortisseur avant: Mini 8IGHT	Set corpo ammortizzatore anteriore: Mini 8IGHT
LOSB1912	Rear Shock Body Set: Mini 8IGHT	Stoßdämpfergehäuse hinten: Mini 8IGHT	Jeu de corps d'amortisseur arrière: Mini 8IGHT	Set corpo ammortizzatore posteriore: Mini 8IGHT
LOSB1913	Shock Piston Set: Mini 8IGHT	Stoßdämpferkolben Set: Mini 8IGHT	Jeu de pistons d'amortisseur: Mini 8IGHT	Set pistone ammortizzatore: Mini 8IGHT
LOSB1914	Front Shock Shaft Set: Mini 8IGHT	Stoßdämpferkolbenstange Set: Mini 8IGHT	Jeu de tiges d'amortisseur avant: Mini 8IGHT	Set albero ammortizzatore anteriore: Mini 8IGHT
LOSB1915	Rear Shock Shaft Set: Mini 8IGHT	Stoßdämpferkolbenstange Set: Mini 8IGHT	Jeu de tiges d'amortisseur arrière: Mini 8IGHT	Set albero ammortizzatore posteriore: Mini 8IGHT
LOSB1916	Shock Retainer Set: Ball and Cap Set: Mini 8IGHT	Dämpferkappe mit Kugel Set: Mini 8IGHT	Jeu de chapes et rotules d'amortisseur: Mini 8IGHT	Ammortizzatore, set sfera e cappuccio: Mini 8IGHT
LOSB1917	Shock Rebuild Set: Mini 8IGHT	Reparatur set f. Stoßdämpfer: Mini 8IGHT	Nécessaire de réparation d'amortisseur: Mini 8IGHT	Set ricondizionamento ammortizzatore: Mini 8IGHT
LOSB1918	Front Shock Spring Set: Mini 8IGHT	Federnsatz vorne: Mini 8IGHT	Jeu de ressorts d'amortisseur avant: Mini 8IGHT	Set molla ammortizzatore anteriore: Mini 8IGHT
LOSB1919	Rear Shock Spring Set: Mini 8IGHT	Federnsatz hinten: Mini 8IGHT	Jeu de ressorts d'amortisseur arrière: Mini 8IGHT	Set molla ammortizzatore posteriore: Mini 8IGHT
LOSB1921	Front, Rear Gearbox Set: Mini 8IGHT	Getriebegehäuse vorne / hinten: Mini 8IGHT	Carter de différentiel avant/arrière: Mini 8IGHT	Set scatola cambio anteriore, posteriore: Mini 8IGHT

PART #	ENGLISH	DEUTSCH	FRANÇAIS	ITALIANO
LOSB1922	Spur Gear Set: Mini 8IGHT	Zahnräder Set: Mini 8IGHT	Couronne: Mini 8IGHT	Set ruota dentata cilindrica: Mini 8IGHT
LOSB1923	F/R Diff Gear, Housing & Spacer Set: Mini 8IGHT	Differential vorne / hinten m. Gehäuse Set: Mini 8IGHT	Ensemble engrenages, carter et bagues pour différentiel AV/AR: Mini 8IGHT	Ingranaggi differenziale anteriore/posteriore, set alloggiamento e distanziatore: Mini 8IGHT
LOSB1924	Slipper Plate Set: Mini 8IGHT	Rutschkupplung Scheibe Set: Mini 8IGHT	Ensemble de plateaux pour limiteur de couple: Mini 8IGHT	Set piastra pattino: Mini 8IGHT
LOSB1925	Slipper Pad Set: Mini 8IGHT	Rutschkupplung Belag Set: Mini 8IGHT	Ensemble patinant: Mini 8IGHT	Set pastiglie del pattino: Mini 8IGHT
LOSB1928	Diff Outdrive Set: Mini 8IGHT	Diff. Antriebsklauen Set: Mini 8IGHT	Jeu d'arbres de sortie de différentiel: Mini 8IGHT	Set bicchierino differenziale: Mini 8IGHT
LOSB1929	Center Outdrive Set: Mini 8IGHT	Losi Antriebsklaue Set Mitte: Mini 8IGHT	Noix de cardan central : Mini 8IGHT	Set trasmissione centrale: Mini 8IGHT
LOSB1930	O-Ring Set: Mini 8IGHT	O-Ring Set: Mini 8IGHT	Jeu de joints toriques: Mini 8IGHT	Set O-ring: Mini 8IGHT
SPM2322	DX2E DSMR Radio System	DX2E DSMR Fernsteuerung	Emetteur DX2E DSMR	Radiocomando DX2E DSMR
SPMSRS4201	SRS4201 4-Channel DSMR AVC Receiver, Waterproof	SRS4201 4-Kanal DSMR AVC Empfänger, Spritzwassergeschützt	Récepteur SRS4201 4 voies DSMR AVC étanche	Ricevitore SRS4201 4-canali DSMR AVC, impermeabile
SPMS500	S500 Sport Servo	S500 Sport Servo	Servo S500	Servo S500 Sport

OPTIONAL PARTS/OPTIONALE BAUTEILE/PIÈCES OPTIONNELLES/PEZZI OPZIONALI

PART #	ENGLISH	DEUTSCH	FRANÇAIS	ITALIANO
DYN1476	7.4V 2000mAh 2S 30C Li-Po	Dynamite 7,4V 2000mAh 2S 30C Li-Po	Batterie 7,4V 2000mA 2S 30C Li-Po	Batteria 7,4V 2000mAh 2S 30C Li-Po
LOS210001	Clear Body Set: Mini 8T	Losi Mini 8T: Karosserie transp.	Carrosserie transparente : Mini 8T	Set carrozzeria trasparente: Mini 8T
LOS311000	F/R Shock Tower Battery Brace Carbon Set: 8T	Carbon Dämpferbrücke / Akkuhalter	Support d'amortisseurs et de batterie en carbone : Mini 8T	Set torre ammort. anter/poster supporto batteria carbon: 8T
LOS312000	Front CV Driveshaft: 8T	Losi Mini 8T: Antriebswellen Set vorne	Cardan avant CVD : Mini 8T	Albero trasmissione CV anter.: 8T
LOS312001	Rear CV Driveshaft: 8T	Losi Mini 8T: Antriebswellen Set hinten	Cardan arrière CVD : Mini 8T	Albero trasmissione CV poster.: 8T
LOSB1870	Servo Mount Aluminum	Losi Servobefestigung Aluminium: Mini 8	Support de servo en aluminium	Supporto servi alluminio
LOSB1877	Rear Hub Set, Aluminum	Radträger hinten, Aluminium	Jeu de moyeux arrière, aluminium	Set mozzo posteriore, alluminio
LOSB1878	Carrier Set, Aluminum	Achsschenkelhalter Set, Aluminium	Jeu de porte-fusées, aluminium	Set porta-piastre, alluminio
LOSB1879	Spindle Set, Aluminum	Achsschenkelset Set, Aluminium	Jeu de fusées, aluminium	Set albero, alluminio
LOSB1885	Front Suspension Mount Set, Aluminum	Querlenkerhalterset vorne, Aluminium	Ensemble support de suspensions avant, aluminium	Set montante sospensione anteriore, alluminio
LOSB1899	Rear Suspension Mount Set, Alum: Mini 8IGHT	Querlenkerhalterset hinten, Alu.	Ensemble support de suspensions arrière, aluminium: Mini 8IGHT	Set supporto sospensione post., Allum.: Mini 8IGHT
LOSB1920	Lightweight Center Outdrive Set	Losi Antriebsklaue mitte Leichtbau: Mini 8	Noix de cardan central allégées	Set trasmissione centrale leggero
LOSB1926	Lightweight Diff Outdrive Set	Losi Antriebsklaue vorne/hinten Leichtbau: Mini 8	Noix de sorties de différentiel allégées	Set trasmissione diff leggero
LOSB1938	Front Shock Shaft Set Ti-Ni	Losi Kolbenstange vorne Ti-Ni: Mini 8	Tiges d'amortisseurs avant Ti-Ni	Set albero ammort. anteriore Ti-Ni
LOSB1939	Rear Shock Shaft Set Ti-Ni	Losi Kolbenstange hinten Ti-Ni: Mini 8	Tiges d'amortisseurs arrière Ti-Ni	Set albero ammort. posteriore Ti-Ni
LOSB1940	Front Shock Bodies, Hard Anodized	Dämpfergehäuse vorne hart elox.	Corps d'amortisseurs avant, anodisés dur	Corpo ammort. anteriore, anodizzato
LOSB1941	Rear Shock Bodies, Hard Anodized	Dämpfergehäuse hinten hart elox.	Corps d'amortisseurs arrière, anodisés dur	Corpo ammort. posteriore, anodizzato

FRONT/REAR SHOCKS
 STOSSDÄMPFER V/H
 AMORTISSEURS AV/ARR
 AMMORTIZZATORI ANTERIORE/POSTERIORE

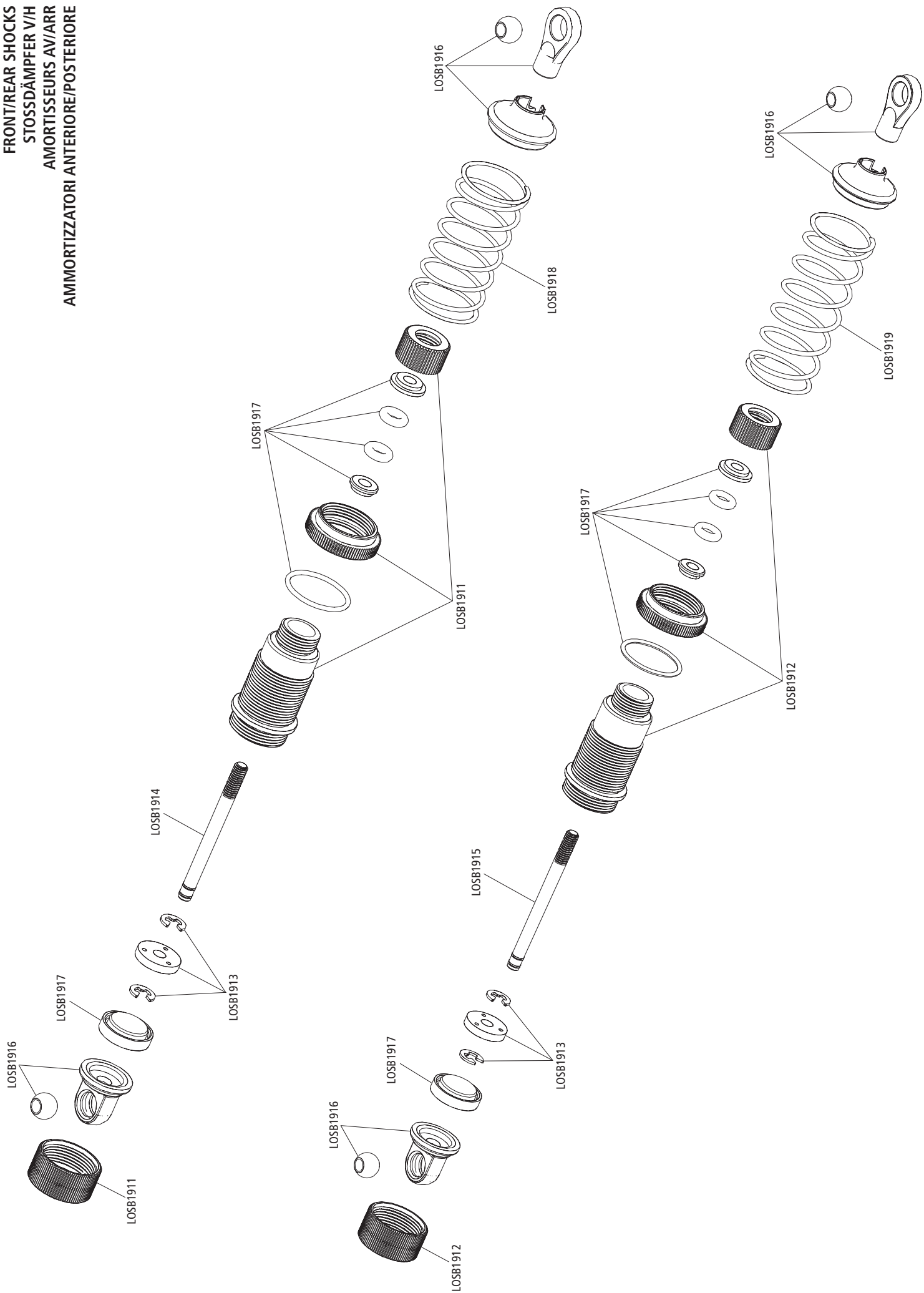



SETUP SHEET



Name: Mini 8IGHT-T

City: _____ State: _____

Front Suspension

Toe: 0 degree

Ride Height: 29.5mm

Caster: Stock

Piston/Oil: 3-hole piston/30 wt

Camber Link: Position 2

Shock Location: Position 2/Inside

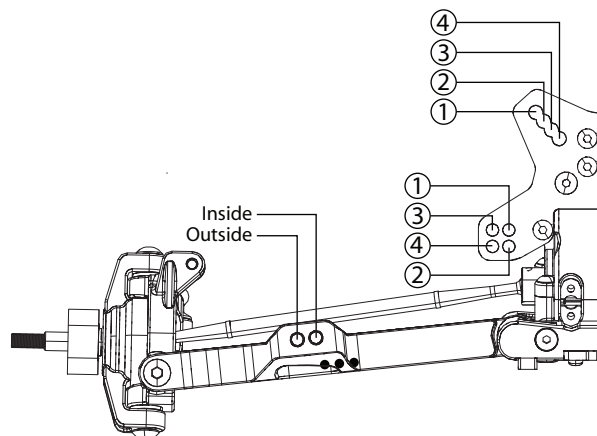

Notes: _____

Rear Suspension

Toe: 3 degrees

Ride Height: 24.5mm

Rear Hub Spacing: Stock

Piston/Oil: 3-hole piston/25 wt

Camber Link: Position 2-B

Shock Location: Position 3/Inside

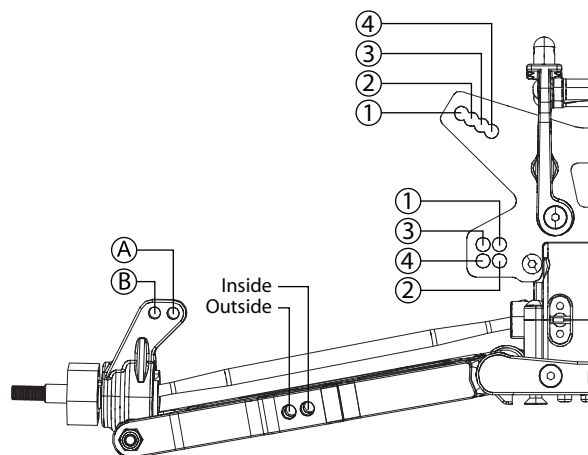

Notes: _____

Electronics

Motor: Fuze 4500Kv

ESC: TAZER Mini Brushless Waterproof ESC

Battery: 1200mAh 7.2V Ni-MH Gearing: 62T/14T

Optimal Battery: 2000mAh 7.4V 2S Li-Po (Gearing: 62T/12T)

Notes



SETUP SHEET



Name: _____

City: _____ State: _____

Front Suspension

Toe: _____

Ride Height: _____

Caster: _____

Piston/Oil: _____

Camber Link: _____

Shock Location: _____

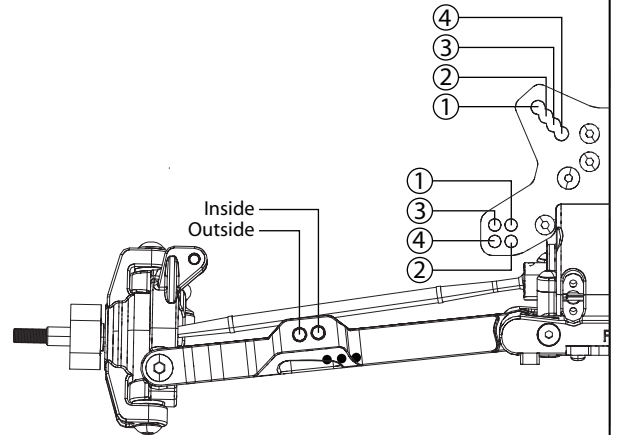

Notes: _____

Rear Suspension

Toe: _____

Ride Height: _____

Rear Hub Spacing: _____

Piston/Oil: _____

Camber Link: _____

Shock Location: _____

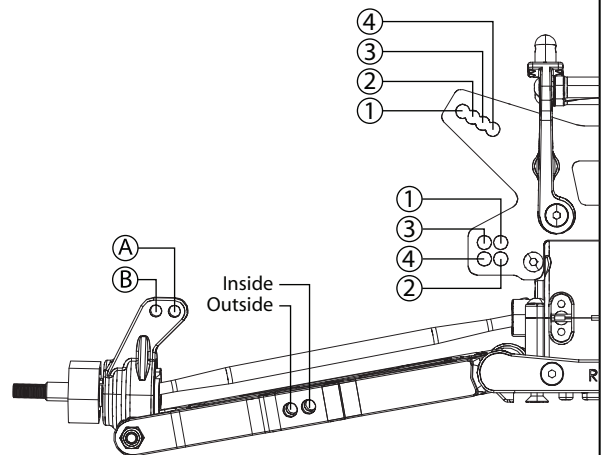

Notes: _____

Electronics

Motor: _____

ESC: _____

Battery: _____ Gearing: _____

Optimal Battery: _____

Notes



SETUP SHEET



Name: _____

City: _____ State: _____

Front Suspension

Toe: _____

Ride Height: _____

Caster: _____

Piston/Oil: _____

Camber Link: _____

Shock Location: _____

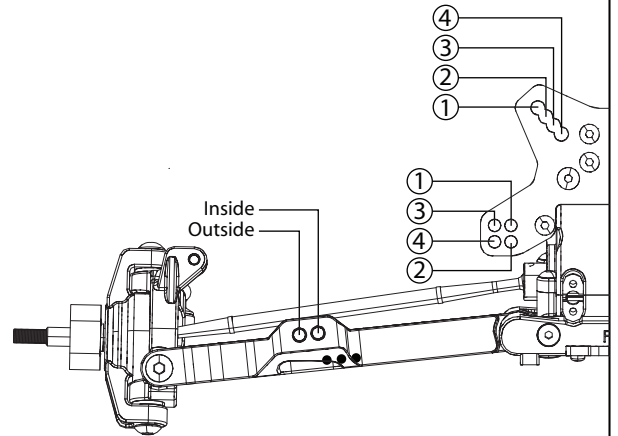

Notes: _____

Rear Suspension

Toe: _____

Ride Height: _____

Rear Hub Spacing: _____

Piston/Oil: _____

Camber Link: _____

Shock Location: _____

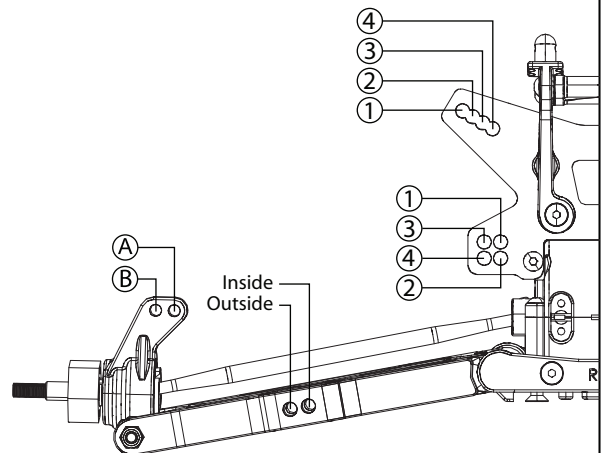

Notes: _____

Electronics

Motor: _____

ESC: _____

Battery: _____ Gearing: _____

Optimal Battery: _____

Notes



WWW.LOSI.COM

46541.2

Created 3/15 LOS010001

©2015 Horizon Hobby, LLC.

Losi, AVC, Active Vehicle Control, 8IGHT-T, DSM, DSM2, DSMR, Dynamite, Fuze, Tazer, EC3, and the Horizon Hobby logo are trademarks or registered trademarks of Horizon Hobby, LLC.

The Spektrum trademark is used with permission of Bachmann Industries, Inc. All other trademarks, service marks and logos are property of their respective owners. Patents pending.