



FLAT-TWIN FOUR STROKE ENGINE

**Gemini**

---

**SERIES**

**OWNER'S  
INSTRUCTION MANUAL**



OSAKA-JAPAN



IMPORTANT: Before attempting to operate your engine, please read through these instructions and separate sheet enclosed so as to familiarize yourself with the controls and other features of the engine. Also, pay careful attention to the recommendations contained in the "Safety Instructions and Warnings" leaflet enclosed.

Your "Gemini Series" engine is a scale-type horizontally-opposed twin-cylinder overhead-valve four-stroke-cycle engine. It is a more powerful development of the FT-120 Gemini introduced in 1979 and further demonstrates O.S. pre-eminence in four-stroke engine manufacture, as first established in 1976 with the introduction of the single-cylinder FS-60 and continued in the latest O.S. single, twin and multi-cylinder models.

Like all O.S. motors, the "Gemini Series" engines are built to standards of skilled craftsmanship that have been developed through sixty years of O.S. production history, a history that is not only the longest in the model engine manufacturing world, but includes such milestones as the world's first and only production model 'Wankel' rotary engine, the world's first quantity-produced model four-stroke-cycle engine and the world's first model aircraft engine to be equipped with a genuine supercharger.

Quality is a watchword at the O.S. factory, which is equipped to a standard unequalled by any other manufacturer in the industry world-wide. Fully computerized modern machinery and the use of carefully selected top quality materials ensure the production of engines of consistent performance and long life.



# Gemini SERIES

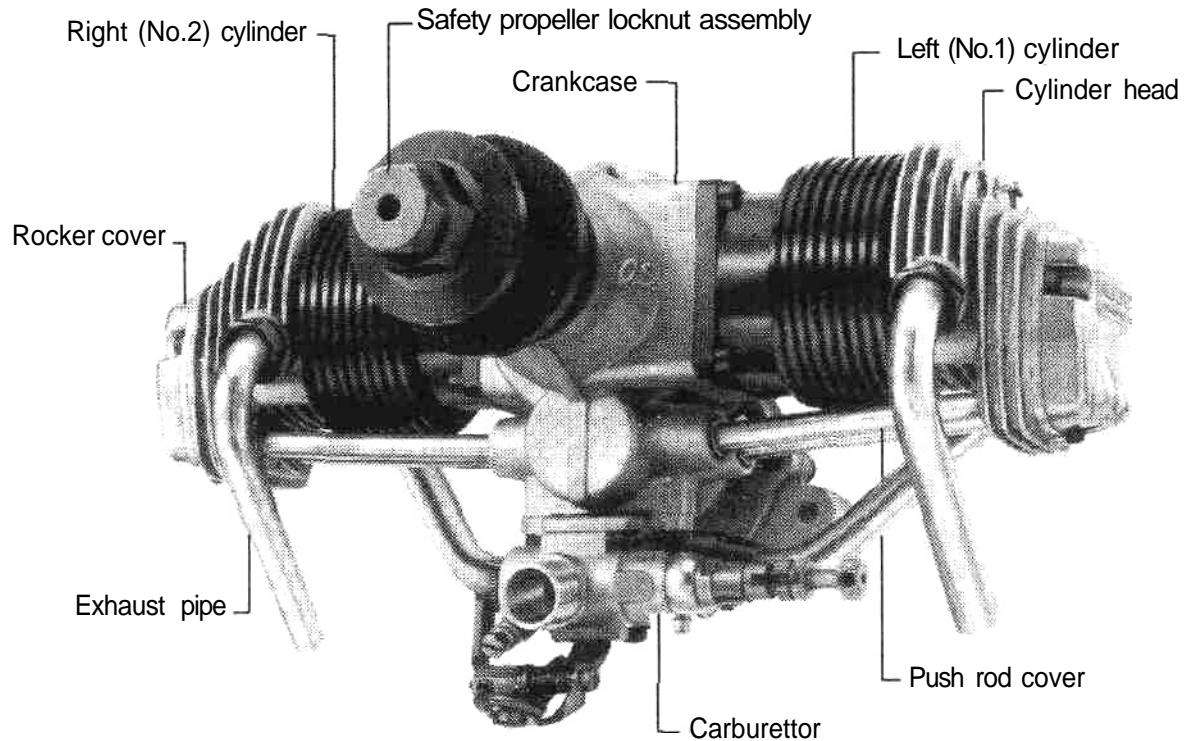

(Photo shows FT-160) There are small differences in the appearance of the other Gemini engines.

**Photo. 1**

# NAMES OF ENGINE PARTS

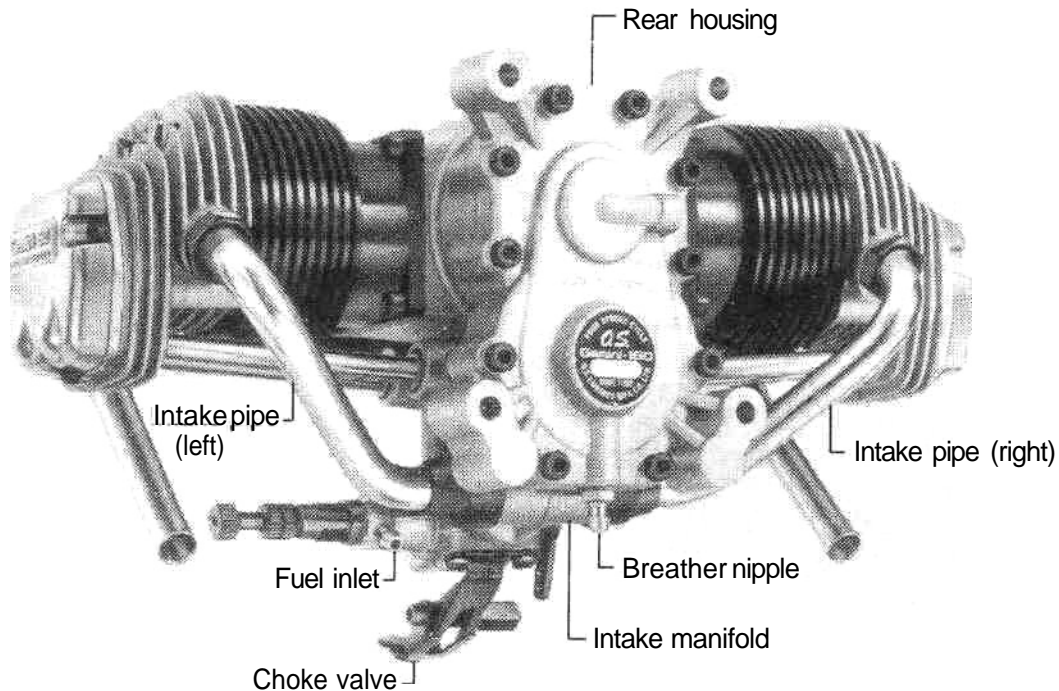
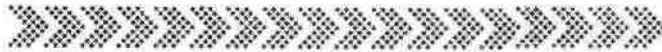

(Photo shows FT-160) There are small differences in the appearance of the other Gemini engines.

Photo. 2

## INSTALLATION

"Gemini Series" engines should be mounted with the carburettor below the crankcase, otherwise scale appearance may be spoiled,

The needle-valve and throttle lever locations are interchangeable and the choke valve rod can be located right or left. Decide their most convenient locations before mounting the engine in the fuselage,

## FUEL TANK

The ideal fuel tank location is with the top of the tank 5-10 mm (1/4-3/8") above the needle valve. However, model design will usually require the tank to be located higher than this and there should be no trouble with such a tank location provided that you do not pursue spectacular acrobatic flight.

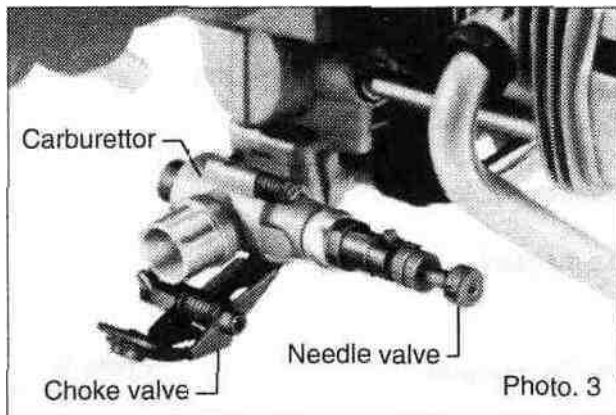

if the tank is located high, fuel will flow into the carburettor when the tank is full. Therefore, pinch the fuel line with a clip, when the engine is not running, to prevent flooding and loss of fuel.

## FUEL

The "Gemini Series" engine runs on standard commercially available model glowplug engine fuel. Fuels containing castor-oil and/or synthetic lubricants are acceptable but, for the best performance and reliability, a fuel containing 5—15% nitromethane is recommended.

*For consistent performance and long life of the engine, it is advisable to use good quality fuel containing AT LEAST 10% lubricant.*

## GLOWPLUG

With a four-stroke engine, ignition of the fuel charge takes place at every fourth stroke of the piston instead of every two strokes. Because of this, conventional two-stroke glowplugs may not suit this engine in some cases. For general use, the special O.S. Type F glowplug is recommended.

## CHOKE VALVE

"Gemini Series" engines are equipped with a spring-loaded choke valve. The choke valve operating lever can be located right or left by reversing the hexagon nut and cap screw. After mounting the engine in the model, secure the L-shaped choke rod by tightening the set-screw. If the rod supplied is too long, reduce it to the required length. If the rod length is more than 40 mm (1-1/2 in.) its outer end should be supported to avoid vibration.

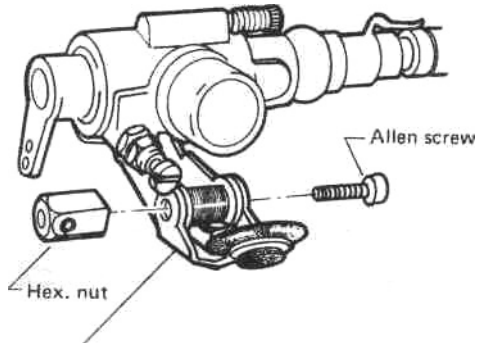

**Fig.1**

Take care that the rubber pad does not become detached.

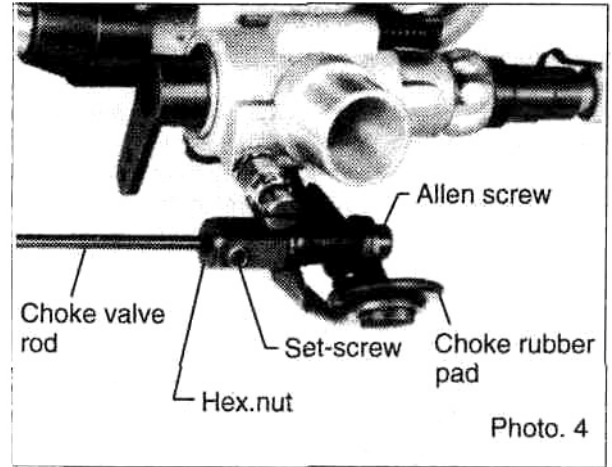

## CARBURETTOR

The needle-valve and throttle lever locations are interchangeable by reversing the carburettor. This can be done as follows:

Remove the carburettor carefully by unscrewing the two screws which secure both carburettor and choke valve. After reversing the carburettor, re-insert it into the intake manifold, taking care not to damage the O-ring in the manifold.

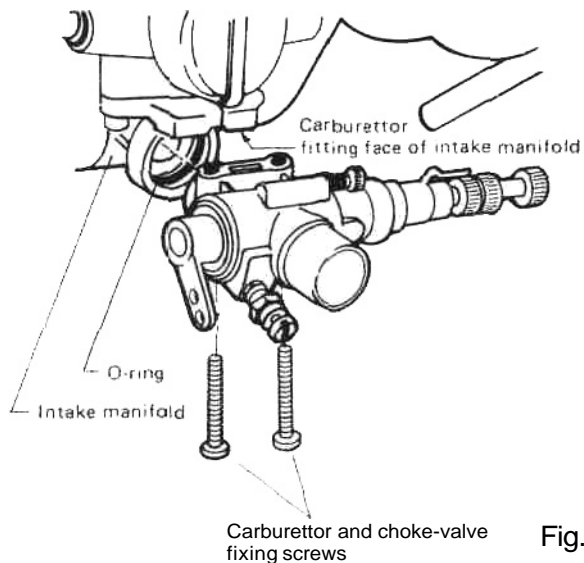
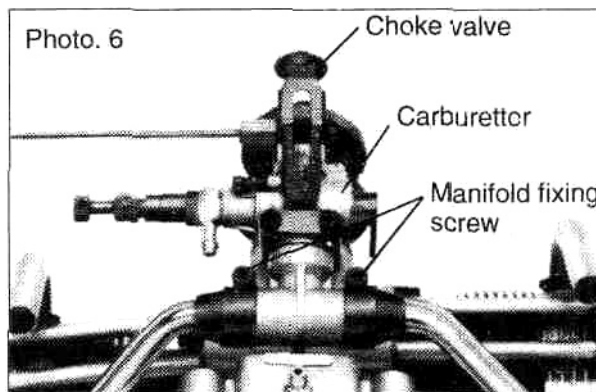
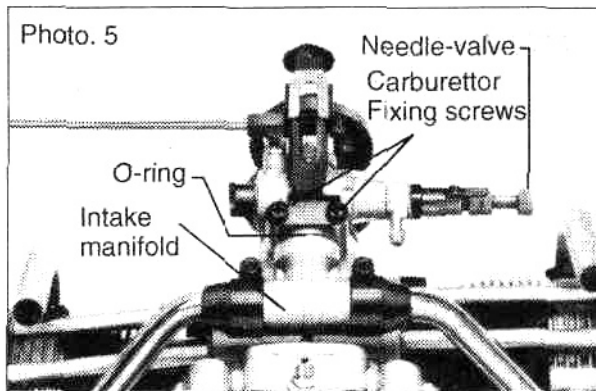

Fig. 2



## PROPELLER

The choice of propeller depends on the size and weight of the model and on the type of flying envisaged. Determine the best size after practical experiment.

Suggested propellers are shown in the separate instructions sheet. For safety, keep your face and other parts of the body well away from the propeller when starting the engine or when adjusting the needle-valve while the engine is running. Remember that the propeller turns through a much wider arc with the larger sized propellers that this engine is capable of driving.

Refer to the "Safety Instructions and Warnings" leaflet enclosed.

**IMPORTANT:** Use well balanced propellers only. An unbalanced propeller causes vibration and loss of power.

The larger displacement O.S. engines were originally designed so that the propeller could be fixed to the engine with screws, as well as the usual nut, in order to prevent propeller slippage. However, if the propeller nut or screws are inadequately tightened, this can (due to detonation or "knocking" if the engine is run too lean or under too heavy a load) cause the propeller to split and fly off. Obviously, this can be very dangerous.

It is recommended, therefore, to use the Safety Propeller Locknut Assembly supplied with the engine to prevent the propeller from fracturing or flying off, even if it loosens.

(See Figs 3, 4 & 5)

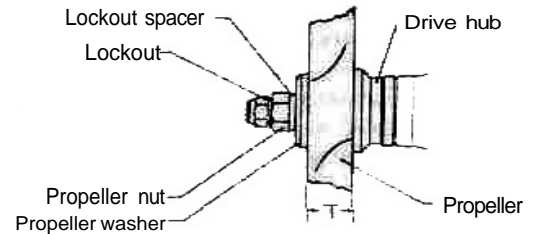

Fig. 3

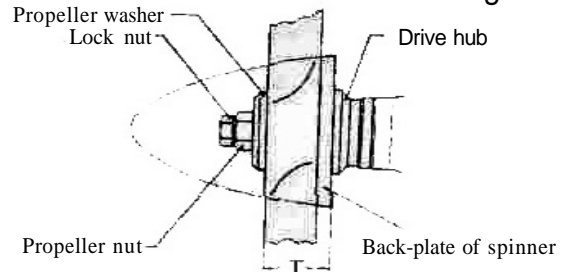

Fig. 4

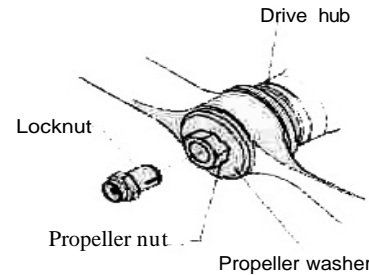

Fig. 5



Installation procedure is as follows:

- 1) Ream the propeller centre hole to the size indicated in the separate instructions sheet. Make sure that the propeller is properly balanced.
- 2) Fit the propeller sleeve-nut and washer to propeller, screw onto shaft and tighten firmly with 17 mm wrench supplied.

If the Safety Propeller Lockout Assembly of your engine is supplied with the Locknut Spacer, add the Spacer if the dimension "T" indicates you should do so, in the separate instructions sheet.

- 3) Finally, insert the Safety Propeller Locknut. Tighten Locknut firmly (but not with excessive force) using 14 mm wrench.

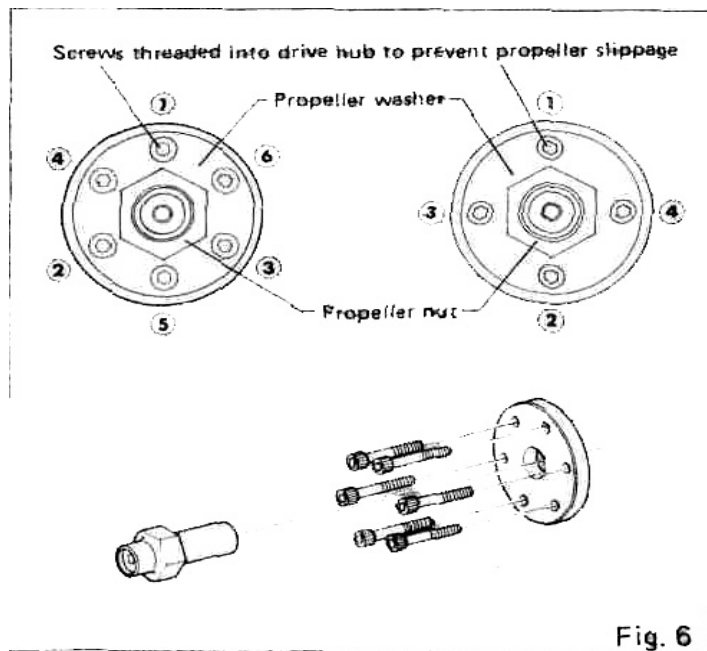

### PROPELLER WASHER SET FOR SCALE MODEL

If you prefer to use the standard prop-nut and retaining screws (see Fig. 6) to obtain more scale-like appearance choose a propeller that has a boss at least as large as the diameter of the drive hub so that it is not weakened when drilled for the retaining screws. If the screws are not used, the propeller may loosen (due to detonation when running or preignition when starting) and, if the engine is running, the propeller will fly off, complete with the retaining nut and washer. This can be very dangerous.

Therefore, secure the prop nut and screws as follows:

- 1) Drill 3 mm diameter holes accurately through propeller boss to exactly align with those in prop washer and drive hub. Do not drill holes oversize.
- 2) Install prop, prop washer, screws and prop nut.
- 3) Tighten prop nut.
- 4) Tighten screws progressively and evenly in the order shown in the sketch.
- 5) Repeat steps 3) and 4) above to make sure that the prop is really secure.

Regardless of the type of propeller fixing used, make a habit of always checking the tightness of the propeller before starting the engine. Remember that, especially with wooden propellers, there is a tendency for the material to shrink, or for it to be reduced by the serrated face of the drive hub.

When removing the propeller from the engine between flying sessions, it is recommended to withdraw it complete with drive hub, instead of removing the six retaining screws. Be careful not to lose the Woodruff key at this time.

(One spare Woodruff key is supplied with the engine.)

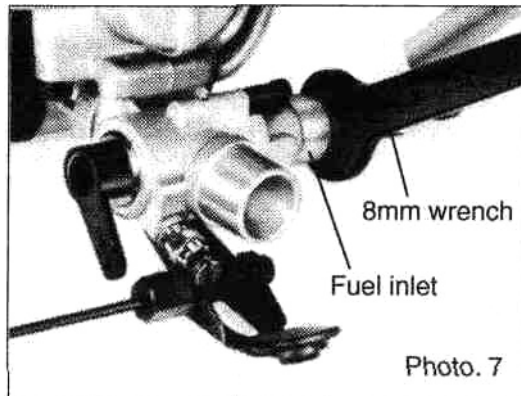

## NEEDLE-VALVE AND FUEL INLET

The needle-valve supplied with this engine is designed to incorporate an extension so that, when the engine is enclosed within the fuselage, the needle-valve may be adjusted from the outside. An L-shaped rod, of 1.6-1.8 mm dia. and appropriate length, should be inserted into the needle's centre hole and secured by tightening the set-screw in the needle-valve knob with the small Alien key provided. For longer extension, it is recommended to use a piece of flexible control cable, together with the knob and support hook supplied. Also, the fuel inlet nipple on the carburettor can be adjusted to the most suitable position for connecting to the fuel delivery tube from the tank. Slacken the needle-valve holder with the 8 mm wrench provided, reset the inlet nipple at the required angle and re-tighten.

## GLOWPLUG WIRING

A set of glowplug leads, with clips, is supplied with the engine. The lug plate of the earth lead should be fastened to the motor mount by means of one of the engine fixing screws.

Observe the following precautions:

- 1) Make sure that no part of the wire or glowplug clip touches the cylinder head or cooling fins.
- 2) Keep wiring away from the fuel tank, where it might cause a fire in the event of a short-circuit.

## Battery Capacity

It is advisable to use a glowplug battery of fairly large capacity (e.g. 20 AH in the case of a rechargeable lead-acid cell) as this is required to heat two glowplugs simultaneously.

## Battery Leads

As the battery leads are required to conduct a large current (approx. 6 amps), make sure that the wire used is heavy enough to prevent excessive voltage-drop at the plugs.

Note: It is inadvisable to use a variable resistance or rheostat as, in the event of one plug lead becoming accidentally detached (or the plug element failing) excessive voltage will be applied to the other plug. The alternative is to use a separate battery and rheostat for each plug.

## STARTING

It is preferable to use an electric starter, although hand-starting is also possible, as will be explained in a moment. When applying the starter, be sure to connect both glow-plugs to the battery.

(It is possible to start the engine on one cylinder only, then to connect the other glowplug to the battery to run the engine on both cylinders, but this is not advisable since it causes needlessly unequal loading of the engine initially.)

- 1) Open the throttle fully and unscrew the needle-valve 3-1/2 turns from the fully closed position.
- 2) It is preferable to use the choke control for priming.
- 3) Close the choke valve and turn the propeller counter-clockwise 2 turns by hand keeping the throttle valve fully open.

**CAUTION:** Never apply an electric starter with the choke closed. Such action will cause an excessive quantity of fuel to be drawn into the cylinder and result in an hydraulic lock that may damage the engine. Do not turn the propeller more than 2 turns, initially, with choke closed, otherwise the engine may suck in too much fuel and become flooded.

- 4) Release the choke control and immediately turn the propeller counter-clockwise several times so that fuel is drawn well into the cylinders.
- 5) Set the throttle valve approximately 1/3 open from the fully closed position. Connect the glowplugs to the battery and apply the electric starter.
- 6) When the engine starts, open the throttle valve fully and keep it running, initially (approx. 10 seconds), with the original needle-valve setting. If the engine slows down because the mixture is excessively rich, close the needle-valve slowly approx. 1/4 — 1/2 turn.
- 7) Now disconnect the battery from the glowplugs and close the needle-valve slowly so that revolutions are increased. Adjust the needle-valve gradually. Abrupt adjustment of the needle-valve may cause the engine to stop, especially when it is new and insufficiently run-in.
- 8) To re-start the engine when warm, simply re-energise the plugs and reapply the starter with the throttle in the idling position. If the engine does not restart, re-prime by closing the choke valve while rotating the propeller twice with the throttle open. Initially, the high temperature inside the combustion chambers may turn the liquid fuel into gas and emit it through the exhaust pipes. Therefore, repeat the priming procedure once or twice until the cylinders become cool enough for restarting.

**CAUTION:** Do not connect the glowplugs to the battery when priming. The adjustment of the needle-valve should be done only after disconnecting the battery from the glowplugs.

## Hand Starting

For safety be sure to use a heavily padded glove or 'chicken-stick'. The procedure is as follows:

- 1) The propeller should be fixed in such a way that it is positioned horizontally as compression is first felt when turning the propeller counter-clockwise.
- 2) Open the throttle valve fully and unscrew the needle-valve 3-V2 turns from fully closed position.
- 3) Close the choke valve and turn the propeller counter-clockwise through two revolutions.
- 4) Release the choke valve and immediately turn the propeller counter-clockwise several times so as to draw fuel well into the cylinders.
- 5) Set the throttle at approximately 1/3 open from the fully-closed position and gradually turn the propeller counter-clockwise until compression is felt.
- 6) Connect the glowplugs to the battery and swing the propeller smartly counter-clockwise from the centre of the right blade. The engine should start. If it stops again, make sure that fuel is reaching the carburettor from the fuel tank, then repeat procedures 3) to 6). Correct priming is the secret of easy starting.
- 7) When the engine starts, open the throttle fully and keep it running, initially (approx. 10 seconds), with the original needle-valve setting. If it slows down because the mixture is excessively rich, close the needle-valve about 1/4 — 1/2 turn.
- 8) Now disconnect the battery from the glowplugs and close the needle-valve slowly so that revolutions increase. Adjust the needle-valve gradually. Abrupt adjustment of

the needle-valve may cause the engine to stop, especially when it is new and insufficiently run-in.

- 9) To re-start the engine when it is warm, after a run, first try just flipping the prop with the throttle in the idling position after re-energising the glowplugs. If the engine does not restart, re-prime it by closing the choke valve while rotating the propeller twice with the throttle open. Initially, high temperature inside the combustion chambers may turn the liquid fuel into gas and emit it through the exhaust pipes. Therefore, repeat the priming procedure once or twice until the cylinders become cool enough for restarting.

**CAUTION:** Do not connect the-glowplugs to the battery when priming.

**Note:** Excess fuel in the carburettor may drip into the engine compartment when the choke valve is reopened. Therefore, it is advisable to drill a drain hole in the bottom of the engine bay or cowl and to apply fuelproof paint to the surrounding surfaces to prevent fuel from penetrating the airframe structure.



## **RUNNING-IN ("Breaking-in")**

For long life and peak performance, please observe the following running-in procedure:

Install the engine and fit the propeller that you propose to use for flying your model. For example, if you use the propeller indicated in the separate instructions sheet, start the engine and run it for about 10 seconds with the needle-valve set for 6,000/6,500 r.p.m., then open the needle-valve to reduce speed to approximately 4,000 r.p.m. and run for 20 seconds at this cooler setting. Keep the throttle fully open, using only the needle-valve to reduce speed.

Repeat this procedure, alternately running the engine fast and slow with the needle-valve, but gradually extending the short period of high speed running until a total of approximately 10 minutes running time has been accumulated. For those who do not have a tachometer, the exhaust gas colour can be a help: i.e., as the needle-valve is screwed in, the dense grey exhaust smoke will become less visible. Following the initial break-in of 10 minutes on the ground, run-in for a further period in the air. For the first flights, have the needle-valve set as rich as possible, consistent with adequate take-off power and, if necessary, readjust the throttle trim on the transmitter so that the engine does not stop when the throttle is fully closed.

With each successive flight, close the needle-valve slightly, until, at the end of 10 flights, the needle-valve is set for maximum power. The carburettor can now be adjusted for optimum throttle performance following the advice given in the separate instructions sheet.

## **VALVE CLEARANCE ADJUSTMENT**

Refer to the INSTRUCTIONS FOR USE OF VALVE ADJUSTING TOOL KIT sheet contained in the Valve Adjusting Tool Kit supplied with the engine.

## **EXHAUST PIPE ADJUSTMENT**

The direction of the exhaust pipe may be altered in accordance with individual installation requirements. The angle is easily adjusted by loosening the nut that secures the exhaust pipe to the cylinder head. Use the appropriate spanner supplied. If longer exhaust pipes are required for the "Super-Gemini" 240/300 models, use the flexible exhaust pipes of 12 cm, 17 cm, 24 cm or 33 cm length which are available as optional extra parts.

## **LUBRICATION**

All the parts of your engine are automatically lubricated by the oil content of the fuel mixture. The crankcase breather hole is in the bottom of the timing case and is fitted with a brass nipple. Fit a length of silicone tubing of approx. 2.5 — 3 mm I.D. to this nipple to conduct away the small amount of oil that escapes through the breather, (see photo 2).

## **CARE OF YOUR "GEMINI SERIES" ENGINE**

Your engine should be treated with the utmost care at all times.

At the conclusion of a flying session, do not leave the engine "wet" with raw fuel by stopping it after rich-mixture running or prolonged idling. Instead, let it run for a few moments at full throttle with the correct needle-valve setting, to bring it up to normal running temperature, then cut off the fuel supply — preferably by removing the fuel line from the carburettor. Extra protection against internal corrosion should be given by injecting some special moisture-displacing oil or light machine oil through the crankcase breather and rotating the crankshaft for several revolutions to draw the oil into the crankcase, etc.

Keep the engine in a clean, dry atmosphere when it is not in use.

When the propeller is removed, replace it with the spacer supplied and tighten the prop nut lightly. This will protect the engine from internal damage in the event of an accidental blow to the crankshaft.

Do not dismantle the engine needlessly.

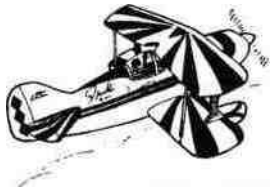

# MEMO

---

---

---

---

---

---

---

---

---

---



## ***O.S.ENGINES MFG.CO.LTD***

6-15 3-Chome Imagawa Higashisumiyoshi-ku  
Osaka 546-0003, Japan TEL. (06) 6702-0225  
FAX. (06) 6704-2722

**URL:** <http://www.os-engines.co.jp>



# INSTRUCTIONS FOB O.S. FT-160 (GEMINI-160) TWIN-CYLINDER FOUR STROKE ENGINE

**IMPORTANT:** Before attempting to operate your engine, please read through this instruction sheet, as well as the GEMINI SERIES Owner's Instruction Manual supplied, so as to familiarize yourself with the controls and other features of the engine. Also, pay careful attention to the recommendations contained in the "Safety Instructions and Warnings" leaflet also enclosed.

The O.S. FT-160 (Gemini-160) is a horizontally-opposed twin-cylinder overhead-valve four-stroke-cycle engine of 26.5cc (1.62cu.in) displacement. It has the same external dimensions and appearance as the FT-120-11 (Gemini-11) but, whereas the Gemini-11 is restricted to 19.9cc (1.21 cu.in) to bring it within the 20cc displacement limit for FAI Class F4C R/C Scale events, the Gemini-160 takes advantage of slightly bigger cylinders, providing more power for non-restricted events, or for sport flying.

Like the Gemini-II, the Gemini-160 is a very refined engine. The horizontally-opposed layout, typical of modern light aircraft engine design, provides very smooth running qualities and docile, trouble-free handling characteristics.

Production of the Gemini-160 and the Gemini-II — as with their big brothers, the 40cc Super-Gemini and the 49cc Super-Gemini-300 — was preceded by an exhaustive programme of research and prototype testing. These engines are, needless to say, built to the outstandingly high engineering standards for which O.S. engines are famous worldwide.

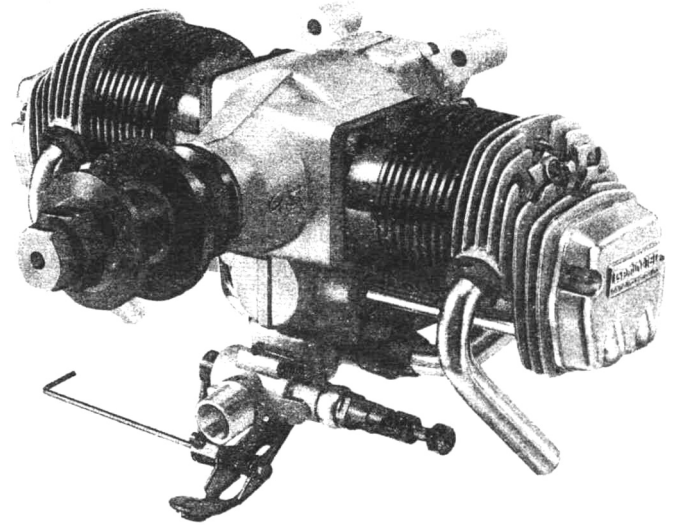

## SPECIFICATIONS

|                  |                            |
|------------------|----------------------------|
| Displacement     | 13.26c.c.X2(0.809cu.in.X2) |
| Bore             | 27.7mm (1.091 in.)         |
| Stroke           | 22.0mm (0.866in.)          |
| Practical R.P.M. | 2.000-10.000               |
| Weight           | 1,100gr. (38.8oz.)         |

## TOOLS AND ACCESSORIES

The following tools and accessories are supplied with your Gemini 160.

1. Radial Motor Mount Set:
  - Radial Motor Mount . . . . . 1
  - Mount Fixing Screws (M5 x 25) . . . . . 4
  - Lock Washers (05) . . . . . 4
  - Blind Nuts (M5) . . . . . 4
  - Engine Fixing Screws (M4 x 22). . . . . 4
2. Set of leads for wiring glowplugs
  - Leads for glowplug with clip . . . . . 2
  - Lead for earth (ground) . . . . . 1
3. Valve Adjusting Tool Kit
  - 0.04mm . . . . . 1
  - 0.10 mm . . . . . 1
  - Hexagonal (Alien) key (1.5 mm) . . . . . 1
  - Wrench (5 mm) . . . . . 1
4. Needle-valve extension cable . . . . . 1
5. Knob for needle-valve extension (with set-screw) . . 1
6. Hook for needle-valve extension . . . . . 1
7. Choke valve rod . . . . . 1
8. Woodruff key (spare) . . . . . 1
9. Scale Propeller Washer Set
  - Propeller washer . . . . . 1
  - Propeller nut . . . . . 1
  - Screws to prevent propeller slippage (M3 x 32) . . . 4
10. Hexagonal (Alien) key (2.0 mm) . . . . . 1
11. Hexagonal (Alien) key (2.5mm) . . . . . 1
12. Hexagonal (Alien) key (3.0mm) . . . . . 1
13. Wrench (5-6 mm) . . . . . 1
14. Wrench (7-8 mm) . . . . . 1
15. Wrench (10-12 mm) . . . . . 1
16. Wrench (14-17 mm) . . . . . 1

## FUEL TANK

The suggested fuel tank size is 400 cc or 14 oz. This will give approximately 10 minutes running time at full power, or about 13-15 minutes when some part-throttle operation is included. Fuel consumption also depends, of course, on the size of propeller used.

## PROPELLER

The choice of propeller depends on the weight of the model and on the type of flying envisaged. Determine the best size and type after practical experiment. As starting points, suggested propellers are 15 X 8, 16 X 6-8, 18 X 6-8 and 20 X 6. If the Safety Propeller Locknut Assembly is used, installation procedure is as follows.

- 1) Ream the propeller center hole to 12 mm (0.472"). Make sure that the propeller is properly balanced.
- 2) Fit the propeller sleeve-nut and washer to propeller, screw onto shaft and tighten firmly with 17 mm wrench supplied. Please refer to 'PROPELLER' section of GEMINI SERIES Owner's Instruction Manual. If the dimension "T" is between 14.5 mm and 18 mm (or 0.571" and 0.709"), add locknut spacer supplied as shown in Fig. 4. If the dimension "T" is between 18 mm and 22.5 mm (or 0.709" and 0.886"), it is not necessary to add the spacer.
- 3) Finally, insert the Safety Propeller Locknut. Tighten Locknut firmly (but not with excessive force) using 14 mm wrench.

## CARBURETTOR ADJUSTMENT

The carburettor of your Gemini 160 has been factory set for the approximate best result, but the setting may, in some cases, vary slightly in accordance with fuel and climatic conditions.

Remember, also, that, while the engine is being run-in and the needle-valve is set on the rich side, the carburettor cannot be expected to show its best response. Therefore, it is recommended that you first run the engine with the throttle settings as received. If, however, the desired throttle response is not obtained after the completion of the running-in period, the carburettor should be re-adjusted as follows.

**Note:** Idling speed adjustments should be carried out with the fuel tank not more than half-full and with the battery disconnected from the glowplugs.

- 1) Start the engine, with the throttle 1/3 open from the fully closed position, then open the throttle fully and gradually close the needle-valve until the engine is running at its maximum speed.

**CAUTION:** Do not close the needle-valve to too "lean" a setting as this will cause the engine to overheat and slow down. Set the needle-valve very slightly to the "rich" side of the peak r.p.m. setting. Make sure that the engine is fully "broken-in" (about 1 hour of total running time in short runs) before operating it continuously at full throttle.

- 2) Now, close the throttle gradually. The engine should idle continuously and steadily. If it does not, adjust as follows.
  - a) If the engine begins to idle unevenly, first re-open the throttle. If the engine hesitates before picking up to full speed, it is probable that the idling mixture is too rich. Check this by closing the throttle again and letting the engine idle for a little longer before again opening up. If the engine now puffs out a good deal of smoke and hesitates or even stops, it will be necessary to screw out the air-bleed screw to weaken the mixture. Do this by turning it counter-clockwise. About 1/2-1 turn should be sufficient.
  - b) If, instead of being too rich, the air-bleed screw is set too lean, the engine will stop when the throttle is closed, or will lose speed while idling and then cut-out abruptly (without smoking) when the throttle is opened again. In this case, turn the air-bleed screw about 1/2-1 turn clockwise.
- 3) When the mixture, has been corrected, the idling speed will probably increase. Re-adjust the throttle opening by means of the throttle trim on the transmitter or by screwing-out the throttle-stop screw so that the lowest

possible idling speed, without stopping the engine, may be obtained.

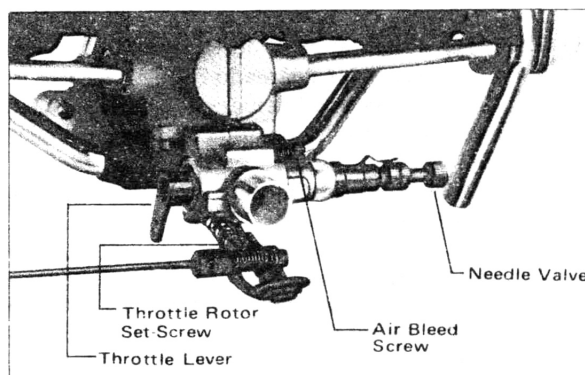

- 4) It is recommended to repeat procedure 2) several times until the best result is obtained.

#### Subsequent Operation and Care

Once the required carburettor settings have been established, it should be unnecessary to alter them. Such slight needle-valve alterations as may be needed to cope with differences in atmospheric conditions or fuels, do not affect the other two adjustments.

It is important that the carburettor operates under clean conditions. Make sure that the fuel is properly filtered before use. We advise fitting a filter in your fuel can and another in the delivery tube between tank and engine, to reduce the risk of the carburettor jet becoming partially clogged and upsetting running adjustments. Remember to clean the filters occasionally.

## PARTS LIST

| Code No. | Description                       | Code No.  | Description                      |
|----------|-----------------------------------|-----------|----------------------------------|
| 46101000 | Crankcase                         | 45361000  | Rocker Arm Assembly (1 pc.)      |
| 46101800 | Rear Housing                      | 45961400  | Rocker Support Assembly          |
| 46102000 | Crankshaft                        | 46162000  | Camshaft                         |
| 46103100 | Cylinder Liner                    | 45564000  | Cam Follower (2 pcs.)            |
| 45903200 | Piston                            | 46166000  | Push Rod (2 pcs.)                |
| 46103300 | Cylinder Jacket                   | 45566100  | Push Rod Cover Set (2 pcs.)      |
| 45403400 | Piston Ring                       | 46168000  | Intake Manifold                  |
| 46104020 | Cylinder Head (w/valve assy)      | 46168500  | Manifold Seal (2 pcs.)           |
| 46104110 | Cylinder Head                     | 46168100  | Intake Pipe (right)              |
| 46104200 | Rocker Cover                      | 46168200  | Intake Pipe (left)               |
| 46105000 | Connecting Rod Assembly           | 46169000  | Exhaust Pipe (1 pc.)             |
| 45906000 | Piston Pin                        | 45471000  | Breather Nipple (w/gasket)       |
| 46108000 | Drive Washer                      | 46109400  | Propeller Spacer                 |
| 45508200 | Woodruff Key                      | 46181000  | Carburettor Complete             |
| 46120000 | Thrust Washer                     | 46184000  | Choke Valve Assembly             |
| 46110100 | Propeller Locknut Set             | 71615009  | Glow Plug Type F                 |
| 46013002 | Screw Set                         | 72200060  | Valve Adjusting Tool Kit         |
| 46114000 | Head Gasket Set                   | 72200040  | Booster Cable Set                |
| 26731002 | Crankshaft Bearing (front)        | 46130000  | Scale Propeller Washer Set       |
| 22130004 | Crankshaft Bearing (intermediate) | 72200080  | Needle-valve Extension Cable     |
| 46030008 | Crankshaft Bearing (rear)         | 71910000  | Radial Motor Mount Set           |
| 46031005 | Camshaft Bearing (front)          | *46110200 | 5/16-M5(L) Propeller Lockout Set |
| 22631019 | Camshaft Bearing (rear)           | *72403050 | Super Filter (large)             |
| 46160000 | Valve Assembly (1 pc.)            |           |                                  |

\* Optional Parts

The specifications are subject to alteration for improvement without notice.

## O.S.ENGINES MFG.CO.,LTD

6-15 3-chome Imagawa Higashisumiyoshi-ku  
Osaka 546, Japan. TEL. (06) 702-0225  
FAX. (06) 704-2722